

Planning

Stratford-on-Avon

District Design Guide

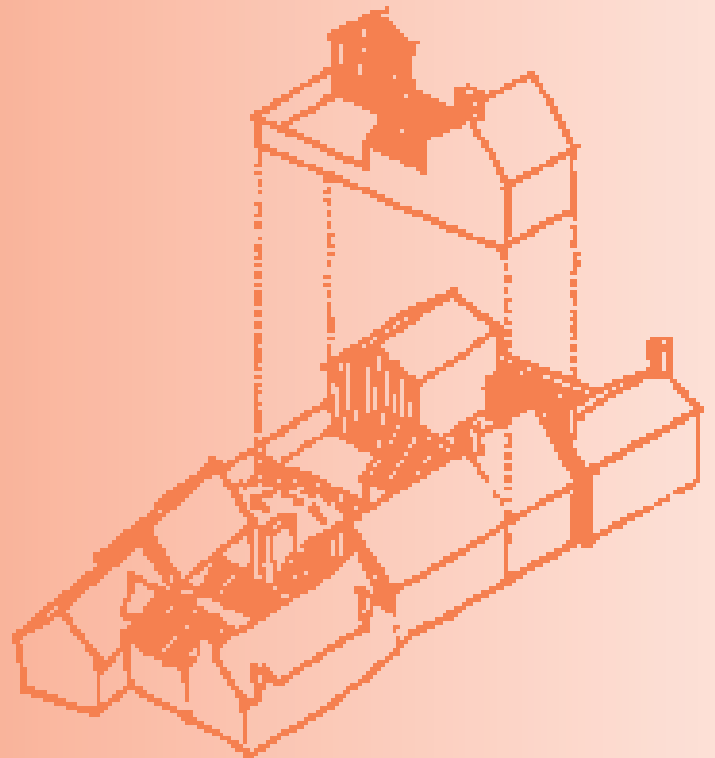

Stratford-on-Avon

**District
Design
Guide**

SDC/0425/APR01

£18.00

ISSUE 1

APRIL 2001

If you find the text in this booklet difficult to read
we can supply it in a format better suited to your needs

Published by Stratford-on-Avon District Council, April 2001

© Stratford-on-Avon District Council

Planning

Stratford-on-Avon District Council
Elizabeth House, Church Street
Stratford-upon-Avon CV37 6HX

Telephone 01789 267575

Facsimile 01789 260306

Minicom 01789 260747

DX700737 STRATFORD-ON-AVON 2

e-mail karl.kropf@stratford-dc.gov.uk

website www.stratford.gov.uk

This guide was produced, in part, with the participation of District Council Members, District and County Council officers and members of the public. The guide builds on the Countryside Design Summary adopted as Supplementary Design Guidance in September 1998. Character mapping and descriptions are based on the *Warwickshire Landscapes Guidelines*, produced by Warwickshire County Council in partnership with the Countryside Commission.

Editorial and Production Team

Editor: *Karl Kropf*

Editorial team: *John Marshall, Andrew Wharton, Ruth Rose, Sally Griffiths, Viv Evans Mark Sturgess, Simon Payne, Jelle Koenen, Hugo Alefs*

Layout and production: Stratford-on-Avon District Council
Design & Cartographic Division

Printed by: Stratford-on-Avon District Council
Central Printing Division

The mapping contained in this guide is reproduced from the Ordnance Survey mapping with permission of The Controller of Her Majesty's Stationery Office. © Crown Copyright. Unauthorised reproduction infringes Crown Copyright and may lead to prosecution or civil proceedings.

Stratford on Avon District Council. Licence No. 100024287. 2001

Published for planning design guidance. Use of this document is limited to viewing on-line and printing one copy.



Table of Contents

Introduction	1	Looking at the design of Plots	49
0.1 The purpose of the guide		7.1 Variation and position	
0.2 How the guide works		Corner plots	
0.3 The structure of the guide		7.2 Building position	
0.4 Context and support		Frontage set-back	
		Orientation to street	
Fundamental Concerns	3	7.3 Density	
1.1 Quality and design of the public realm		7.4 Gardens and boundary features	
1.2 Character and identity		7.5 Parking	
1.3 Sustainability and health		Looking at the design of Buildings	55
1.4 Why the concern?		8.1 Variation and position	
1.5 Actual and visual density		8.2 Form, components and innovation	
1.6 Standard minimum dimensions		8.3 Extensions	
1.7 Highway design		8.4 Non-residential buildings	
1.8 Design, character and innovation		Looking at the design and choice of Details and materials	61
The Character of Stratford-on-Avon District	7	9.1 General principles	
2.1 A general description		9.2 Examples and specific principles	
2.2 A character map of Stratford-on-Avon District		Appendix A Conversion of traditional agricultural buildings	71
2.3 Character areas and descriptions		A.1 The principle of conversion	
Arden		A.2 The setting of the barn	
Feldon		A.3 Existing structure	
Cotswold Fringe and Ironstone Uplands		A.4 Repairs	
Avon Valley		A.5 New structure	
Stour Valley		A.6 Windows and doors	
Basic principles	13	A.7 Roofs	
3.1 A viewpoint on design		A.8 External walls	
3.2 The importance of specific features		A.9 Extensions	
3.3 Character and sustainability		Appendix B Shopfronts and signage	75
3.4 Using a settlement as a design resource		B.1 General considerations	
3.5 Innovation with a purpose		B.2 Shopfronts	
Looking at the design of Settlements	23	B.3 Signs and advertisements	
4.1 Design and landscape		Appendix C List of principal villages in character areas	79
4.2 The settlement as a whole in the landscape		Appendix D Species lists	83
4.3 The internal arrangement of settlements		Appendix E Sample planting specification	87
4.4 Movement and street patterns		Appendix F Sources of local stone	89
4.5 Landscape and open space as a network			
Looking at the design of Streets	39		
5.1 The street as a unit of character			
5.2 Variation of character and position			
5.3 The extent of the street			
5.4 The parts and arrangement of a street			
5.5 Visual integration within streets			
Looking at the design of Highways, open spaces and plot series	43		
6.1 The components			
6.2 Highways			
Other sources of guidance			
Highways and open spaces within the street			
Design and use			
Carriageways, footways and islands			
6.3 Plot series			





Subtle but identifiable differences characterise the landscapes and settlements of Stratford-on-Avon District. The photos above show the rolling landforms and honey coloured stone of the Cotswold Fringe area and the more subtly undulating topography of the Avon and Stour Valleys with their brick and timber frame buildings.



Preface

On the face of it, a street is an ordinary thing. Streets are everywhere. We live and work along them. We use them most every day to do the things we want to do. But while streets may be part of everyday life, they are not all the same. From a High Street to a small back lane, each route has its own distinctive character and identity. And each town or village, with its particular mix of streets, is equally distinctive. The closer you look the more you find the differences.

If this guide has a single overall aim it is to encourage people to look carefully at what makes places different. As the guide makes clear, the idea of the street is a handy way of pulling those things together. The character of a town or village has a lot to do with the character of its streets and lanes - not just the way they look but also the way they are used and cared for.

The idea of character is central to this document. All the seemingly minor features that make a place different add up to a distinctive character. The landscape of Stratford-on-Avon District is not as dramatic as some but it is distinct and recognisable in its smaller details. It is also diverse. On the surface the differences may appear subtle but the diversity is evident in many ways, from street patterns to building materials. The character map included at the beginning of the guide shows the wide range of different areas that make up the District.

Diversity and character are not the result of a single act of design. The places that we appreciate so much in our District are the product of a continuous process of change involving many people over many years. The challenge we face now, and in the future, is to manage that change in order to foster and protect the identity of place. Planning must be a positive force for achieving a balance between innovative, imaginative change and the positive qualities of the environment as it comes down to us.

Stratford on Avon District Council is developing and using a range of methods and techniques to instil local character in new development and ensure what we do is sustainable. Village Design Statements and Parish Appraisals, prepared by the public, are already influential in planning decisions. The District has also been active in pursuing a number of initiatives under Local Agenda 21.

I welcome this Guide as another tool the Council has for improving the quality of the environment and achieving development that is local, sustainable and equitable. The District deserves nothing less.

Robert Stevens

Leader, Stratford on Avon District Council





The Arden and Feldon areas pictured above have been identified as distinct areas since at least the Middle Ages. The more wooded Arden has dispersed settlements of mainly timber frame and brick while the more open Feldon is characterised by compact settlements predominantly of Lias stone.



Introduction

- 0.1 The purpose of the guide
- 0.2 How the guide works
- 0.3 The structure of the guide
- 0.4 Context and support

The purpose of the guide

0.1.1 The purpose of this guide is to provide design guidance to applicants for planning permission, including Listed Building Consent, Conservation Area Consent and Express Consent for advertisements, in Stratford-on-Avon District. The main objective of the guidance is to help secure designs that are:

- Local
- Sustainable
- Equitable

How the guide works

0.2.1 As a working document, the guide is intended to serve as a common source of information and guidance for all those involved in the planning process. It is not intended as a detailed account of all parts of the District nor a source of ready-made design solutions. Rather, the guide sets out a range of general issues and principles concerning design that the Council regards as necessary to consider in formulating specific designs.

0.2.2 Applicants for planning permission, including Listed Building Consent, Conservation Area Consent and Express Consent for advertisements, must demonstrate in the material submitted that they have given due consideration to the issues and principles set out in this guide in the formulation of proposed designs. For details concerning specific documents, drawings and other information required with applications, please refer to application forms and Stratford-on-Avon District Council's Planning Practice Notes.

0.2.3 To achieve the objectives of this guide, the central focus is the distinctive, local, qualities of the District. The guidance works on the basis that new development should share some of the characteristics that define the area in which it is located. It should be clear that the new development has features in common with buildings and landscapes of a similar kind in the surrounding area. The guide sets out general principles and methods to help achieve this aim. Also, as becomes clear in the guide, **achieving designs that are local can make a significant step toward achieving development that is sustainable and equitable.** The focus on character does not mean the other two main considerations are any less important.

0.2.4 The application procedure should, in outline, involve the following:

- check the proposal is acceptable in policy terms;
- determine requirements to be accommodated on site as set out in the District Local Plan and Planning Practice Notes and Development Briefs if applicable;
- identify the character area, as described in this guide or the Stratford-on-Avon District Character Map, within which the development is proposed;
- read the information regarding that area in this document and any relevant Village Design Statement, Conservation Area or other document;
- by visiting the site and using this guide, identify the specific characteristics that make up the site and the area in which the development is proposed;
- discuss proposals with planning and conservation officers;
- demonstrate, in text and graphics, that the design submitted shares a sufficient number of those characteristics or justify their absence.

The structure of the guide

0.3.1 The guide is divided into nine principal chapters and six appendices. The first chapter covers the fundamental concerns motivating the production of this guide. The second includes a character map of Stratford-on-Avon District with descriptions of the different character areas within the District. The third chapter introduces some basic principles of design. Chapters four to nine cover more detailed issues of design working through levels of scale from the settlement as a whole in the landscape down to materials and details. The appendices cover more specific and technical matters.

Context and support

The relationship of this guide to other policy and guidance documents

0.4.1 This document is meant to be used alongside a number of others that set out policy and guidance relating to design. The diagram below shows the position of this guide within the structure of policy and guidance operating in Stratford-on-Avon District. Those documents higher up the list cover larger areas. In the case of supplementary planning guidance, the documents are intended to be complementary. Those covering smaller areas provide more detailed advice limited to a particular area. The documents listed below are bound A5 or A4 documents unless otherwise noted.

Policy

- Regional Planning Guidance for the West Midlands Region
- Warwickshire Structure Plan
- Stratford-on-Avon District Local Plan

Supplementary Planning Guidance

Countywide

- *Warwickshire Landscapes Guidelines*
- *Roads and Transport for Developments*

Districtwide

- *A Rural Strategy for Stratford-on-Avon District*;
- *Planning Practice Notes*;
- **THIS GUIDE - Stratford-on-Avon District Design Guide**;
- *Countryside Design Summary for Stratford-on-Avon District*, a summary of the District Design Guide in poster format;
- *Access Design for People with Disabilities*, advisory leaflet;
- *Landscape Design: Advice for new development sites*, advisory leaflet;

Individual settlements or parts of settlements

- *A Sustainable Parking Strategy for Stratford-upon-Avon*;
- Village Design Statements, in various formats;
- Parish Appraisals;
- Conservation Area Documents;
- *Signs and Advertisements in Conservation Areas*, advisory leaflet;

Specific sites

- Development Briefs

0.4.2 Guidance in this document supersedes previous advice contained in the *Design Guide for Residential Conversion of Redundant Farm Buildings*.

0.4.3 The emerging Local Bio-diversity Action Plan and documents issued by the Cotswold Area of Outstanding Natural Beauty Joint Advisory Committee may also contain relevant policy and guidance for particular parts of the District.

0.4.4 Support for this guide is provided at various levels including, Planning Policy Guidance notes PPG1(Revised): *General Policy and Principles*, PPG3, *Housing* and PPG7 (Revised): *The Countryside-Environmental Quality and Economic and Social Development*; the companion guide to Design Bulletin 32, *Places, Streets and Movement*; the DETR/CABE guide, *By Design*, the Countryside Agency's Countryside Character programme; Warwickshire Structure Plan 1996-2011; the Stratford-on-Avon District Local Plan and the Stratford on Avon District Council Eco-Management and Audit Scheme Environmental Programme. The guide was initiated by Council resolution and was produced, in part, with the participation of Council Members, District and County Council officers and members of the public including specialists in geology, landscape, ecology, architecture, urban design and history.

0.4.5 This guide builds on the Countryside Design Summary adopted as Supplementary Planning Guidance by the Strategy Committee on 7 September 1998. The core, objective information used in identifying the character areas was provided by the *Warwickshire Landscapes Guidelines*, produced by Warwickshire County Council in partnership with the Countryside Commission.

0.4.6 A Consultation Draft of this guide was circulated for a period of six weeks from 28 April to 9 June 2000. 600 copies were issued to a list of consultees that included District and County Council Members, Parish/Town Councils/Meetings, District and County Council Officers, neighbouring Councils, amenity bodies and civic societies, housebuilders, developers, housing associations, architects and other agents operating in the District as well as relevant academic institutions.

0.4.7 This Guide was adopted as supplementary planning guidance by the Stratford-on-Avon District Council Planning and Regulation Committee on 18 September 2000.

Fundamental Concerns

1

- 1.1 Quality and design of the public realm
- 1.2 Character and identity
- 1.3 Sustainability and health
- 1.4 Why the concern?
- 1.5 Actual and visual density
- 1.6 Standard minimum dimensions
- 1.7 Highway design
- 1.8 Design, character and innovation

Quality and design of the public realm

1.1.1 There are several concerns that have prompted this guide. One of the foremost is the overall quality of our environment. Of particular concern are the streets, lanes, squares and greens that make up our villages and towns - more generally, the *public realm*. This concern is based on the idea that any new development involving *public* streets or spaces entails a responsibility on the part of *private* individuals or groups. That contribution should be seen to improve the quality and character of the public realm for the benefit of the community as a whole. This is a general concern that has been voiced at the national level in the form of recent documents and Planning Policy Guidance Notes such as *Quality in Town and Country*, PPG1 (Revised), PPG3 and *By Design*. These documents have firmly established design as a material consideration in planning. The Stratford-on-Avon District Design Guide is intended to clarify the Council's position toward design in that context.

Character and identity

1.2.1 Another, related concern is the identity and distinctiveness of the towns, villages and landscapes in the District. A common complaint is that new development tends to look the same wherever you go. In many cases developers strive to establish a national profile at the expense of local character. The things that make places special, from street pattern to individual buildings and materials, are too often ignored or at risk. Again this is a concern that has been voiced at the

national level. Recent documents such as PPG 1 (Revised), PPG3, *By Design* and the companion to Design Bulletin 32, *Places, Streets and Movement* underline the importance of maintaining the characteristics and features that give places their identity. The guidance in this document aims to provide more specific means for identifying local character and creating new designs that enhance the unique character and qualities of the District for the good of both present and future generations.

Sustainability and health

1.3.1 A further general concern is the short and long term health of the environment. At the local level, the priorities of the District Council include promoting environmental sustainability, in particular accessibility, rural transport, conserving energy and resources and reducing pollution. This concern is reinforced at the national level within the realm of planning in PPG 1 (Revised) which gives it top priority under the general description of sustainable development. The implications of sustainable development run through all levels of design from the location of development to the orientation of buildings down to the choice of building materials. Consequently, the issue is dealt with throughout this guide as opposed to being left to a separate section.



High Street, Alcester, Arden area, the principal public street in the town



House built of local Hornton stone, Avon Dassett, Cotswold Fringe area



Hedge laying in Alderminster, Stour Valley area

Why the concern?

1.4.1 A concern for the quality and character of the environment suggests something is not quite right with the way things are going. What are the problems that give this impression? In outline they are the negative sides of the three concerns noted above. **New development appears to be diminishing the quality and accessibility of the public realm. It seems to be eroding the character and identity of places and putting its long term health at risk.**

Actual and visual density

1.5.1 Dealing in particular with residential development, there are a number of specific aspects of recent designs that give cause for concern. One is the actual and visual



A rural village,
Preston Bagot, Arden Area



A small town centre,
Shipston-on-Stour, Stour Valley area



Dense suburbia,
Long Itchington, Feldon area

density of development. This issue needs to be seen in relation to traditional rural villages on the one hand and the historic cores of larger villages and towns on the other. Rural villages generally have a very low density and significant areas of open space and planting both in private gardens and public greens. Connection to the countryside is also much more direct. In contrast, the historic centres of larger villages and towns tend to be built at higher densities with terraced and attached buildings creating a distinct building line and well defined street spaces.

nor the well defined building line and street space of the town. There is little or no space for significant planting but there is no positive definition of the street space.

Highway design

1.7.1 A further problem with dense suburban development is that standard minimum dimensions are also applied to the street itself in isolation from the arrangement of the houses. Because these standards are applied uniformly it contributes significantly to the apparent uniformity of new development and its lack of local character. Where existing villages and towns may have a main street with a wide carriageway, wide grass verge and a row of trees contrasting with side streets with only narrow pavements, new development is almost exclusively

made up of a standard width carriageway and standard width pavements. This problem is most pronounced in larger developments where it is often difficult to tell one street from another. **Often, in an effort to break up the potential monotony of such layouts, the houses are arranged in groups. The groups tend to have little relation to the arrangement of streets and the result is merely a fragmentation of the street with backs and sides of houses facing the street in an unco-ordinated and disorienting way.**

Standard minimum dimensions

1.6.1 The sense of crowding in new development, which might be called 'dense suburban', is due to a number of factors arising from the attempt to create a suburban ideal using minimum dimensions. The ideal is a detached house set back from the street and surrounded by garden with significant trees and planting. The reality is a detached house set back only far enough to allow for car parking which takes up most of the front garden while side gardens are reduced to the minimum, often as little as 2 metres, and the back garden is limited to 11 metres in order to achieve the conventional minimum distance of 21 metres between the backs of houses. **The effort to use detached houses in a space better suited to terraced houses has the benefits of neither the rural village or town ideal. It gives neither the open space and planting of the rural village**

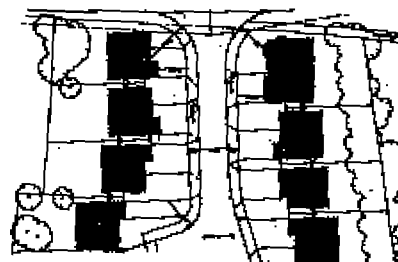

A dense suburban
layout applying
minimum standard
dimensions

1.7.2 The common use of culs-de-sac with standard dimension turning heads raises a number of issues. **One consequence of cul-de-sac development is that it tends to concentrate traffic at the base of the street. All traffic must come in and go out by the same route.** Particularly if there is a large ‘tree’ arrangement with several smaller culs-de-sac leading to streets that feed into a ‘distributor’ cul-de-sac, the traffic at the base of the ‘trunk’ of the tree will be very heavy. **The quiet at the top is paid for with the increased traffic, noise and pollution at the bottom.**

In cases where there is a large cul-de-sac with several branches, **the response is often to orient the houses solely onto the culs-de-sac. The road that serves the culs-de-sac is thus transformed into a corridor almost exclusively for the motor car.** It is not enlivened by the fronts of houses with windows and front doors facing the street, people working on gardens, getting in and out of cars, going in and out of houses. Rather, the street is lined by blank walls or fences, an environment that is generally inhospitable to the pedestrian.



A result of cul-de-sac development: a blank, inhospitable estate distributor road

1.8.4 The aim of the guidance in this document is to make use of the connection between tradition and innovation and get away from the polarisation between the two. The guide recognises that just as traditions do not have value purely because they are old and established, innovations do not have value purely because they are new and fashionable. **Both traditions and innovations must have a purpose and ideally more than one. They must fit into the web of people’s current activities and interests. This guide encourages innovation but innovation with explicit purposes within a particular, local context.**

Design, character and innovation

1.8.1 The principal way this document seeks to address the issues raised above is through the idea of character. Another way of saying ‘character’ is to say identity or distinctiveness. **Character is the combined effect of all those features that make a place identifiable.** What are those features? It could be said that everything matters - all the features you could point out. Such a definition is clearly unworkable in practice. **For the purposes of this guide, the descriptions and principles will focus on a selection of aspects that contribute to the character of the countryside and settlements in the District.**

1.8.2 The selection has been based on the need to choose characteristics that are readily observable as well as readily taken as considerations in design. Again, the central focus of this design guidance is the distinctive, local, qualities of the District. The basis of the guidance is that new development should share some of the aspects that contribute to the character of the settlement in which it is located.

1.8.3 The focus on the idea of character and local distinctiveness is not intended to be a barrier to innovation. Rather it should be seen as a kind of filter and stimulus for innovation. Local distinctiveness is a specific context in which the energy and vitality driving innovation can be channelled and focused in particular directions. Tradition and innovation are not pure and absolute entities. Today’s tradition was yesterday’s innovation. One cannot exist without the other. They are tied together in the longer term process of communities, global and local, working and living in particular places and responding to particular circumstances.



New house, Loxley, Feldon area. The design demonstrates a modern reinterpretation of a traditional, local type

The five main character areas within Stratford-on-Avon District



The Character of Stratford-on-Avon District

2

- 2.1 A general description
- 2.2 A character map of Stratford-on-Avon District
- 2.3 Character areas and descriptions
 - Arden
 - Feldon
 - Cotswold Fringe and Ironstone Uplands
 - Avon Valley
 - Stour Valley

A general description

2.1.1 In looking at the character of Stratford-on-Avon District it is worthwhile to note that character is not entirely a matter of the physical aspects of a place. Firstly, the location of the District within a larger context influences its perceived character. The setting and surrounding regions - the places you have to go through to get to the District - contribute to its identity. This consideration underlines the fact that character is only possible to identify by comparison and the contrasts between one place and another. **Secondly, character involves far more than the bricks and mortar of a settlement. The human activities that have taken place and continue to take place in a settlement also make a significant contribution to character.** The character of the District is the result of an extended historical development, involving many generations of people living and working in particular places.

2.1.2 Stratford-on-Avon District lies in Midland England in the county of Warwickshire. It is a rural district corresponding to the southern third of historic Warwickshire and encompasses the historic towns of Stratford-upon-Avon, Henley-in-Arden, Alcester, Shipston-on-Stour and Southam. The general character of Stratford-on-Avon District is one of rolling lowland countryside, much of it arable farmland. That character is all the more obvious when compared with such areas as the flat fenland of the east Midlands, the mountains of the Peak District or the estuaries of Essex. A closer look reveals, however, that Stratford-on-Avon District lies at the confluence of several broader character areas and its own character is far from uniform. The geological features and climate of the area and the impact of several thousand years of people living and working on the land have created a landscape of subtle but real variation. Travelling from north to south, for example, the differences are clear. The hamlets, winding lanes and small fields of the more wooded Arden in the north-west give way to the open areas of grazing and larger scale fields of the Avon and Stour valleys with their closely built villages. From there, south, the ground rolls gently to the steep scarp slope of Edgehill and the downland of the Cotswold fringe. The downland and broad valleys are marked by medium scale fields of arable and pasture, dotted with compact stone villages. These differences form the basis for identifying distinct regions within the District. These regions, or character areas, in their turn provide the basis for design guidance. The features taken into

account include the underlying geology, the landform, the variety and number of trees and other plants, the shape and size of fields and the way they are managed, the pattern of roads and settlements and their internal structure and the building materials out of which the towns and villages are made.

A character map of Stratford-on-Avon District

2.2.1 There are five main character areas within Stratford-on-Avon District as shown in the map to the left: the **Arden**, the **Avon and Stour Valleys**, the **Cotswold Fringe**, the **Feldon** and the **Ironstone Uplands**. The Feldon and Arden correspond in large part to historically recognised regions. The terms Arden and Feldon were current by medieval times. Arden derives from the British *ardu* meaning 'high, steep', Feldon from the Old English *feld* meaning 'open land'. Further, early settlements and agricultural activity tended to centre on river valleys, principally the Avon, Arrow, Alne and Stour. It is also notable that while the District is an administrative entity with 'artificial' boundaries, many of those boundaries correspond to 'natural' boundaries such as river basin divides. The District lies almost entirely within the drainage basin of the River Avon. The northern and southern boundaries of the District fall approximately on the divides with the greater basins of the Rivers Trent and Thames.

2.2.2 Each of the character areas is further divided into sub-areas to account for more local differences. The areas and sub-areas are intended to provide a general record of the character of the district as a whole but is not intended to account fully for the details that make places unique. The boundaries identify areas in which there is a degree of similarity in terms of landscape and settlement pattern. The character map and later chapters of this document describe some of the general similarities as well as differences that make each area identifiable.

See **Appendix C** for a list of settlements indicating the character area in which they are found.

Character areas and descriptions

Arden

2.3.1 Birmingham plateau fringe (a)

- Gently rolling land form, the upper end of the River Blythe basin, draining north to the Trent with no clearly defined valley;
- Belts of mature trees associated with estates; many ancient woodlands, small in size and often with irregular outlines; areas with a well defined pattern of small fields and paddocks; thick roadside hedgerows, often with bracken;
- A network of minor lanes with scattered hamlets and ribbon development;
- Main building materials are timber frame and brick;

2.3.2 Ancient Arden (b)

- Varied undulating land form with occasional steep scarp slopes, principally draining to the River Alne without a clearly defined basin;
- Hedgerow and roadside oaks; an ancient irregular pattern of small to medium sized fields; field ponds associated with permanent pasture;
- A network of winding lanes and trackways often confined by tall hedgebanks; many scattered hamlets and farmsteads, mostly on slope sides with larger villages or towns on hilltops or valley bottoms;
- Main building materials are timber frame and brick with some Arden Sandstone and Blue Lias Limestone;

2.3.3 Alne and Arrow valley floors (c)

- Middle reaches of the Alne and Arrow rivers in fairly distinct basins, the edges defined by narrow floodplains extending to large scale rolling land form;
- Winding hedgerows along the edge of the floodplain; grazing meadows, often with patches of wet grassland; a semi-regular pattern of medium to large sized fields; mature hedgerow and roadside oaks;
- A varied settlement pattern of small villages and scattered farmsteads, generally lying near a river or stream;
- Main building materials are timber frame, brick and Blue Lias Limestone;

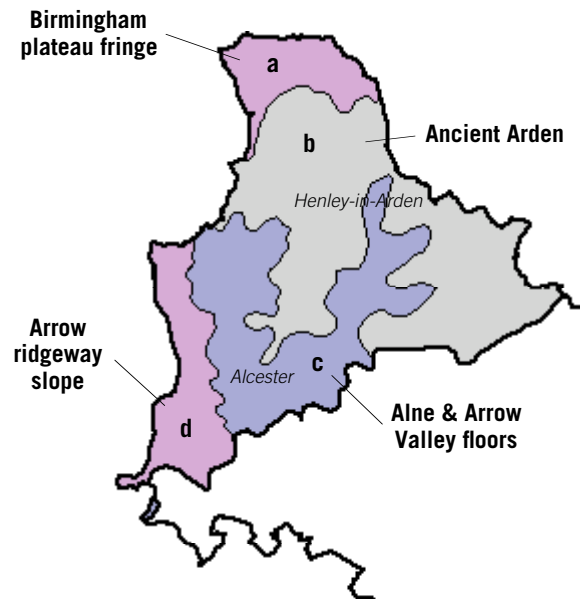

2.3.4 Arrow ridgeway slope (d)

- Higher side of the River Arrow basin, including dividing ridge and ridgeway; large scale rolling land form with occasional steep scarp slopes;
- Large woodlands, often associated with rising ground; mature hedgerow and roadside oaks; a semi-regular pattern of medium to large sized fields;
- Very few small villages and scattered farmsteads; Main building materials are timber frame, Blue Lias Limestone and brick;

Feldon

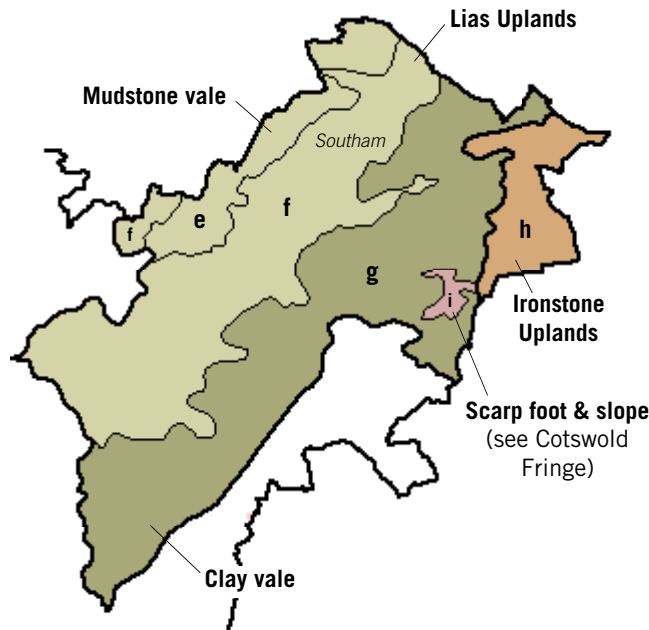

2.3.5 Mudstone vale (e)

- Small flat valley with occasional small rounded hills, draining to the Avon at right angles to the line of the valley; a further area forms the foot of the River Itchen;
- A medium to large scale geometric field pattern; small areas of permanent pasture often with well preserved ridge and furrow; wide roadside verges typically bounded by a thick hedge and ditch; numerous hedgerow elm stumps;
- Scattered farmsteads and dwellings and the village of Long Itchington;
- Main building materials are Blue Lias Limestone and brick;

2.3.6 Lias uplands (f)

- A varied rolling land form often associated with steep wooded scarp slopes, mostly draining to the Rivers Dene and Itchen without clearly defined basins;
- Many hedgerows and roadside trees; well defined geometric pattern of small to medium sized fields; disused quarries with semi-natural grassland and scrub
- Compact villages sited on hill and ridgetops, hill sides and along narrow valley bottoms;
- Main building materials are White Lias Limestone (now known as Langport Member Limestone), Blue Lias Limestone and brick;

2.3.7 Clay vale (g)

- Broad flat valley with occasional small rounded hills, the valley running at right angles to the lines of the Rivers Stour, Dene and Itchen;
- A medium to large scale geometric field pattern; small areas of permanent pasture often with well preserved ridge and furrow; wide roadside verges typically bounded by a thick hedge and ditch; numerous hedgerow elm stumps;
- Relatively few, straight roads with few, small compact villages sited by streams along with scattered farmsteads and dwellings;
- Main building materials are Blue Lias Limestone, 'Hornton Stone' (Marlstone Rock Bed) and brick;

Ironstone Uplands

2.3.8 Ironstone Uplands (h)

- Large scale rolling upland with occasional prominent ironstone hills, includes the divide between the Rivers Leam and Cherwell; it is the western edge of the Northamptonshire Uplands yet at the same time a continuation of the Cotswold/Edge Hill scarp;
- Large scale strongly hedged field pattern; small areas of permanent pasture with ridge and furrow; wide roadside verges bounded by tall, thick hedgerows; steep hillsides with semi-natural grassland and scrub;
- Small ironstone villages often situated on rising ground;
- Main building material is 'Hornton Stone' (Marlstone Rock Bed);

Cotswold Fringe

Clay Vale (g) (see Feldon)

2.3.9 Scarp foot and slope (i)

- The scarp slope leading down to the broad flat Feldon Clay Vale, the scarp and vale running at right angles to the lines of the Rivers Stour, Dene and Itchen;
- Semi-improved grassland, scrub and wood on steep valley sides; a medium to large scale geometric field pattern on the foot of the scarp; small areas of permanent pasture often with well preserved ridge and furrow; wide roadside verges typically bounded by a thick hedge and ditch;
- Small compact villages sited at the foot of the scarp slope; many dry stone walls;
- Main building materials are ‘Hornton Stone’ (Marlstone Rock Bed) and brick;

2.3.10 Ironstone plateau and valleylands (j)

- Flat land at the top of the scarp slope, deeply cut by steep sided river valleys, draining to the Cherwell, the scarp edge forming the divide between the greater Thames and Severn basins; Steep wooded slopes; large arable fields with red soils on the plateaux; semi-improved grassland and scrub on steep valley sides;
- Roads run along ridgetops; small compact villages sited at the rim of the valleys and dropping down along the valley sides; many dry stone walls;
- Main building materials are ‘Hornton Stone’ (Marlstone Rock Bed) and brick;

2.3.11 Fringe downlands (k)

- A varied rolling land form of rounded or flat topped hills and secluded river valleys; includes Meon Hill, Ilmington Downs, and Brailes Hill;
- A medium to large scale geometric field pattern; rich red soils supporting productive arable farmland with some woodland on higher ground; small areas of permanent pasture often with well preserved ridge and furrow; steep hillsides with semi-improved grassland and scrub;
- Small compact stone villages, mostly sited on ridgetops or the foot of the scarp slope; many dry stone walls;
- Main building materials are ‘Hornton Stone’ (Marlstone Rock Bed), ‘Cotswold Limestone’ (Oolitic Limestone) and brick;

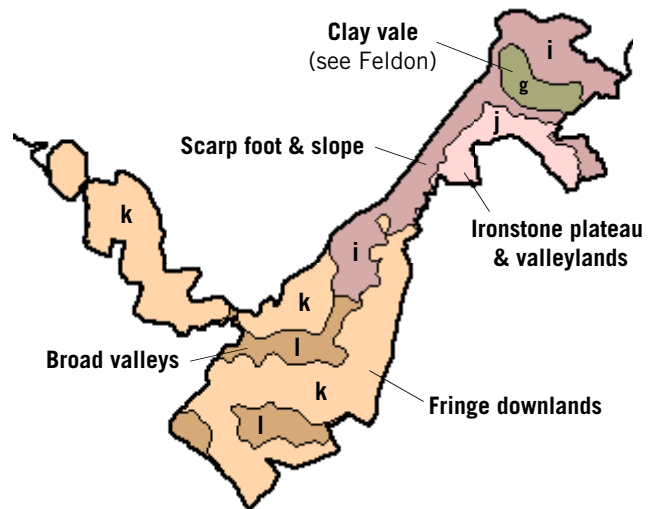

2.3.12 Broad valleys (l)

- Valley floors with some varied undulation and small rounded hills;
- A medium to large scale geometric field pattern with small areas of permanent pasture often with well preserved ridge and furrow;
- Small compact stone villages, mainly on the valley bottoms; many dry stone walls;
- Main building materials are ‘Hornton Stone’ (Marlstone Rock Bed), ‘Cotswold Limestone’ (Oolitic Limestone) and brick;

Avon Valley

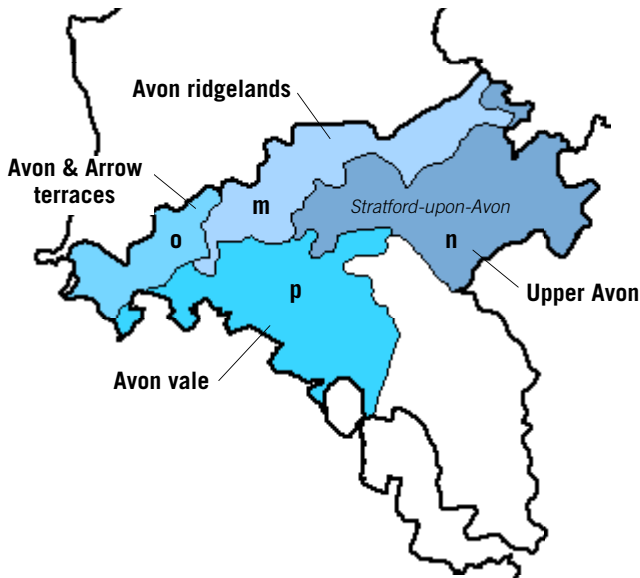

2.3.13 Avon ridgelands (m)

- Steeper side of the Avon basin including the ridge dividing the Rivers Avon and Alne with a large scale rolling land form;
- A large scale often poorly defined field pattern; some large orchards on hilltops and south facing slopes; prominent hilltop woodlands; steep wooded scarps and associated semi-improved grassland;
- Varied settlement pattern of small compact villages, mostly on hilltops and ridges, and loose clusters of roadside dwellings;
- Main building materials are Blue Lias Limestone and brick;

2.3.14 Upper Avon (n)

- Flatter side of the upper reach of the Avon basin; narrow river corridors defined by flat floodplains with steeply sloping, often wooded bluffs to the north west side extending to broad flat gravel terraces on the south east side;
- Grazing meadows often with meanders, islands, steep banks and much marginal vegetation; fringing alders and scrub; winding hedgerows and ditches along the boundary of the floodplain; a large scale geometric field pattern on the terraces with well wooded streamlines and some small arable plots growing a wide variety of vegetable crops;
- Small compact villages generally on or next to to a river; scattered greenhouses and other horticultural buildings;
- Main building materials are timber frame, Blue Lias Limestone and brick;

2.3.15 Avon and Arrow terraces (o)

- Broad flat gravel terraces at the meeting of the rivers Arrow and Avon;
- A large scale geometric field pattern; some small arable plots growing a wide variety of vegetable crops; well wooded streamlines;
- Small compact villages, generally on or next to to a river; scattered greenhouses and other horticultural buildings;
- Main building materials are timber frame, Blue Lias Limestone and brick;

2.3.16 Avon vale (p)

- Flatter side of the lower Avon basin; narrow river corridors defined by flat floodplains with steeply sloping, often wooded bluffs extending out to broad flat valley with occasional low rounded hills;
- Grazing meadows often with meanders, islands, steep banks and much marginal vegetation; fringing alders and scrub; winding hedgerows and ditches along the boundary of the floodplain; a medium to large scale geometric field pattern on the valley land with many small often abandoned orchards;
- Straight roads with wide roadside verges typically bounded by a tall hedge and ditch; a strongly nucleated settlement pattern of medium sized villages, often fringed by greenhouses or other horticultural buildings;
- Main building materials are timber frame, Blue Lias Limestone, 'Cotswold Limestone' (Oolitic Limestone) and brick;

Stour Valley

2.3.17 Stour vale (q)

- Flatter side of the lower Stour basin; broad flat valley with occasional small rounded hills;
- A medium to large scale geometric field pattern; small areas of permanent pasture often with well preserved ridge and furrow; wide roadside verges typically bounded by a thick hedge and ditch; numerous hedgerow elm stumps;
- Small compact estate villages and clusters of farmsteads and dwellings;
- Main building materials are Blue Lias Limestone, 'Cotswold Limestone' (Oolitic Limestone), 'Hornton Stone' (Marlstone Rock Bed) and brick;

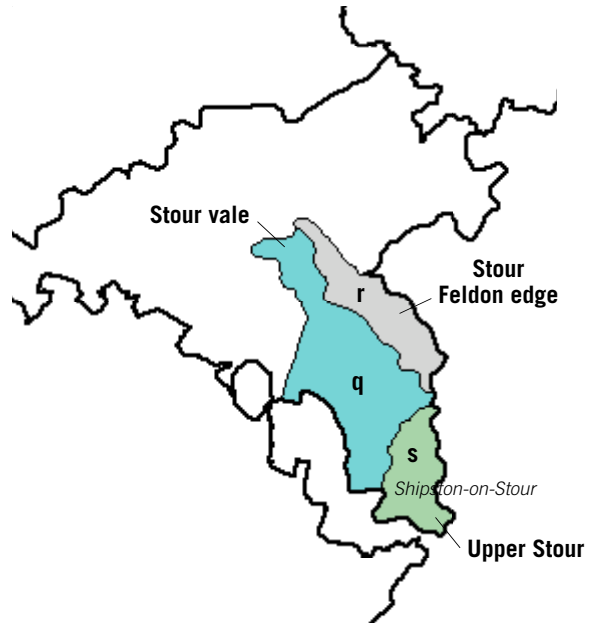

2.3.18 Stour Feldon edge (r)

- Steeper side of the lower Stour basin; large scale rolling land form with occasional steep scarp slopes;
- Large woodlands often associated with rising ground; many small coverts and belts of trees; mature hedgerow and roadside oaks;
- Scattered farmsteads and a small compact village;
- Main building materials are White Lias Limestone (now known as Langport Member Limestone) and brick;

2.3.19 Upper Stour (s)

- Middle reach of the Stour valley, a distinct basin defined by the rounded Tredington hills and the flatter, rolling southern edge of the Feldon;
- A medium to large scale geometric field pattern; small areas of permanent pasture often with well preserved ridge and furrow; wide roadside verges typically bounded by a thick hedge and ditch; numerous hedgerow elm stumps;
- Compact valley bottom settlements and small estate villages;
- Main building materials are Blue Lias Limestone, 'Hornton Stone' (Marlstone Rock Bed), 'Cotswold Limestone' (Oolitic Limestone) and brick;

Basic principles

3

- 3.1 A viewpoint on design
- 3.2 The importance of specific features
- 3.3 Character and sustainability
- 3.4 Using a settlement as a design resource
- 3.5 Innovation with a purpose

A viewpoint on design

3.1.1 To begin, it is important to note that achieving an acceptable form of development involves a balance of issues. Every solution involves a compromise between competing ideals. Achieving one ideal may exclude the possibility of achieving another. While there is no formula for attaching importance to the concerns, the existence of this guide is an indication that quality in design should be given due consideration.

3.1.2 This document sets out ideals that must be balanced with all the other considerations material to planning. In seeking to achieve that balance, the approach recommended here is not, 'does the development meet standards' but 'how can the best design be achieved within the bounds of what is acceptable in other terms.'

3.1.3 In order to establish a workable basis for design guidance, it is worth clarifying what is encompassed by the term design. When we talk about design, we generally talk about **suitability to purpose**. We also talk about the overall shape and size of a thing such as a building. We talk about where it sits relative to other buildings, to the street as well as its position within a block or the village as a whole. We also talk about the way the thing is put together, the parts of the building and the way the parts are arranged. This emphasises that **design involves both the various objects we recognise and the way they are arranged**. Generally speaking, settlements are all made up of the same kinds of elements - buildings, plots, streets, bridges, monuments, greens etc. Each town or village is distinct and has a specific character and identity, however, because it is made up of specific buildings, plots and streets in specific locations.

High Street, Henley-in-Arden, looking north toward St. John's Church and, right, in plan



In general terms, Henley High Street is made up of a carriageway, footways and plots containing buildings. It is a unique place because it is made up of particular examples of those elements in a particular arrangement.

Patterns: objects and arrangements

3.1.4 Whatever the element, an entire street or a single wall, the **design of the element is a matter of both the objects that compose it and the relationship between them.** Design involves selecting things and putting them together in a particular way - into a pattern - in a specific place. We can then talk about the character because we experience the pattern of objects in that particular place.



Drystone wall of Cotswold limestone



Ashlar wall of Cotswold limestone and Hornton marlstone



Concrete block wall

Part-to-whole: a stone within a wall

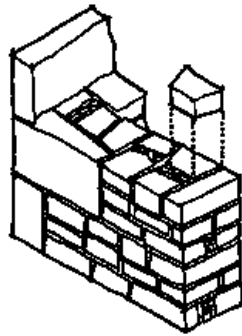

Part-to-whole: a plot within a plot series

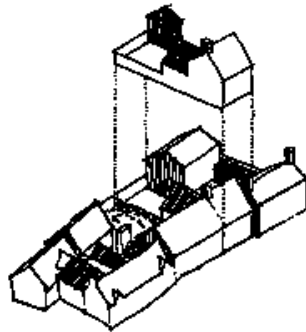

3.1.5 Character is a matter of both material objects and the way they are arranged. Taking the example of a stone wall, as shown above, the character of the wall lies as much in the pattern or arrangement of the stones, (dependent on their shape and size) as in the type, colour, texture and veining of the stone itself. Equally, the character of the wall depends on its overall shape and size as well as where the wall might sit relative to other features.

The part-to-whole relationship

3.1.6 One of the most basic relationships involved in any design is between the object as a whole and its parts. This is the relationship between a wall and the individual stones, for example or between a plot and the row of similar plots running down one side of a street.

3.1.7 The individual plot is a part of the row, which can itself be outlined as a whole. Similarly, the individual plot, as a whole, is made up of a number of different elements such as the main building, the garage or outbuildings, front and back gardens and boundary features.

Levels of scale

3.1.8 Using the part-to-whole relationship, it is possible to look at a settlement at different but related **levels of scale**.

- **Settlements in the landscape**
- **Streets and neighbourhoods within a settlement**
- **Plot series or blocks, highways and open spaces**
- **Plots**
- **Buildings**
- **Details and materials**

A settlement in the landscape, Whichford, Cotswold Fringe area, an element at the highest level of scale



This viewpoint provides the framework around which this guide is built. It is also the basis for one of the more basic design principles.

3.1.9 Any development will fall within some level of scale, as part of something larger and with its own internal parts. Higher and lower levels of scale are important to both large and small scale development. In this regard there are four principal considerations in judging the quality of a proposal:

- its position as part of a larger element (more than one level may be involved);
- its shape and size as a whole (scale, massing);
- the arrangement of parts;
- the specific nature of the parts.

Each of these considerations needs to be seen in terms of the visual and aesthetic impact of the development as well as its relation to the human activities it is meant to accommodate.

The importance of specific features

3.2.1 Despite the importance of pattern, specific features can be of great importance within a settlement. Monuments and landmarks, historic buildings, greens, streets and squares, trees, hedges, gardens and other open spaces in many cases cannot be replaced without a significant loss of character. Such elements tend to persist in settlements because they continue to be valued and recognised as fundamental to the character of the settlement.



A well-head, Ilmington, Cotswold Fringe area, an important specific feature at a lower level of scale

3.2.2 Other features persist, particularly at higher levels of scale, because they take more effort to change. Street patterns, for example, change little over the years. While the buildings may change along them, and the surface of the street might change, the alignment - its position - stays much the same. This persistence contributes to the overall character of the town.

3.2.3 As far as possible, existing features should be carried forward into new development.

3.2.4 In particular it is important to preserve specific features that have been identified as of value due to their historical, archaeological, ecological and geological importance.

3.2.5 As far as possible, traces of the position or arrangement of existing features, if not their substance, should be carried forward into new development. For example, the position and line of paths or routes should be retained in the form of streets or roads, field boundaries as plot boundaries etc. Alternatively, the line or position of a feature might be maintained while the nature of the feature might be changed - replace a boundary with a road, replace a building but retain the building line.

Character and sustainability

Reduced energy use

3.3.1 There is a correlation between the character of settlements due to their historical development and the emerging notion of sustainability. In essence both share the principle of **least energy use** (which is distinct from **least monetary cost**). The form and character of traditional settlements can in part be explained by the limited availability of energy and resources. The persistence of street patterns, as described in the previous paragraph for example, is partly a result of individuals and the community as a whole not being able to afford the labour and material to demolish existing streets and buildings and rebuild them. They used the least energy necessary to achieve an end. Similarly, the use of local materials was based on the same principle. To import materials required more energy, either in the form of human and animal labour or money to pay for them.

3.3.2 Today, the widespread availability and relatively low cost of fossil fuels has changed the equation. While the monetary cost of building, in terms of money and human energy, might be minimised for economy or profit, the total energy cost in terms of fuel used is increased. This makes a much wider range of materials and types affordable and accessible in any given place - contributing to the homogenisation of the built environment and to the depletion of natural resources.

3.3.3 While this is a process that has been going on for nearly two hundred years, it has accelerated in the last fifty. In place of the limits imposed by geography and the state of technology, the notion of sustainability seeks to impose voluntary limits on energy and resource use in order to preserve them for future generations. The principle of least energy use can thus help to achieve the objective that new development be both sustainable and local.

3.3.4 Stated as a general principle, the total energy used in development should be minimised. This must be seen not just in terms of actual construction but in terms of the total cost of the development, from material extraction or production and transport through construction to maintenance and running costs.

3.3.5 Applying this principle to itself suggests that the starting point for sustainability should be low cost, simple solutions.

3.3.6 In general, new development should make the best use of what exists, both natural and built, as opposed to erasing what exists and starting from scratch.

3.3.7 New development should respond to the location. As far as possible, existing levels, watercourses, vegetation, streets, field/plot patterns, buildings and landmarks should be incorporated as part of the design. Alterations to those features should be minimised.

3.3.8 Development should be adapted to the site not the site to the development.

Reduced resource use

3.3.9 Looking at the range of natural resources involved in development, the principle of least energy use can be generalised as one of **temperate stewardship**.

3.3.10 Resources used in development such as land, clean water, clean air, fertile soil and minerals should be minimised. In addition, stocks of the resources should be protected from loss and degradation and, ideally, should be increased. Again, this must be seen not just in terms of actual construction but in terms of the total cost of the development, from material extraction or production and transport through construction to maintenance and running costs.

3.3.11 Waste or loss of resources through consumption or degradation by pollution should be minimised.



Kington in 1885 and 1995. The street pattern has remained essentially the same.



House in Cherington. Local stone has been used for the walls, roof and boundary wall.

Adaptability of built resources

3.3.12 Another principle that ties together character and sustainability is **adaptability**. It is an extension of the least energy use principle but concerns built as opposed to natural resources. Built resources are those that are used but not used up in the way that energy or water are. They include, amongst other things, streets, buildings, car parks, parks and greens. The form and character of many such elements in historical settlements have come about through the necessity of getting the most use out of a building using the least energy and materials. The simple way to do this is to create buildings that can accommodate a number of different activities with little or no change to the building. Also, as buildings are changed over time, those that are most adaptable tend to be retained rather than being pulled down.

A purlin and rafter roof under construction. Easily converted to living space, this type of roof provides greater adaptability in comparison to trussed rafter construction



3.3.13 In some cases, streets for example, the different uses are accommodated at the same time or within a short period. Bridge Street in Stratford, for example, accommodates pedestrians, parked vehicles and moving vehicles at the same time. It also periodically accommodates (at different times) a market, a fair and a ceremonial procession. In other cases, buildings that were originally intended for one purpose are later used for another. Some larger row houses, for example, were originally built to house a single family and later came to serve either as flats for several families or as a shop or offices.

3.3.14 As far as possible, existing built resources should be re-used and adapted with as little change as necessary.

3.3.15 As far as possible, new built resources should be designed as multi-functional elements.

3.3.16 New built resources should be robust and adaptable.

3.3.17 An indication of the specific ways in which these principles can be put into practice is incorporated into the guidance relating to the different levels of scale set out in the following sections.

In summary, it is worth repeating that the starting point for sustainability should be low cost, simple solutions. 'High Tech' or 'Alternative' solutions are not necessarily the most appropriate.

3.3.18 Things do not have to look different to be sustainable.



A large house in Kineton built for a single family now used as a library



A street space in Shipston-on-Stour accommodates access to buildings, walking, driving, parking, shopping and the possibility for many informal activities

Using a settlement as a design resource

3.4.1 The villages and towns in the District, have evolved over a long period of time. The process of their evolution has involved hundreds of years of trial and error accommodating human activities and needs. The result is a diversity of forms, particularly in terms of regional and historical differences. This diversity should be seen as an asset and resource. The various forms that have been developed through active use offer a starting point for new designs which accommodate similar activities.

3.4.2 Such a view treats 'heritage' and the historical built environment not as a museum but as a library. The existing forms of an area can be viewed as potential solutions in the continuing task of accommodating human needs in that place. If particular forms of building have proved satisfactory over time and a core of human needs remains relatively unchanged, those forms provide the most sensible starting point for new ones. Local forms of building that have proved most adaptable provide a basis for new designs that help both to maintain character and offer continued adaptability.

3.4.3 Ensuring that a range of local forms is taken as the starting point promotes the richness of diversity and allows for flexibility of use.

3.4.4 New development should learn from and improve on what has already been done. It should take the existing forms from local settlements, proved through trial and error as potential solutions as a point of departure for any proposed alternatives.

3.4.5 New development should use the experience embodied in the settlements themselves (and in some cases described in Conservation Area documents) and the knowledge of the local population, in particular as set out in parish appraisals and Village Design Statements.

3.4.6 Applicants must show they have exhausted the possibilities identified in such documents before proceeding along different lines.

3.4.7 Look for local solutions first.

3.4.8 Innovate by reinterpretation - make it new AND local.

Market Square, Kington. Different house types in different positions form a clearly defined space



Two different house types used to make the best of a long narrow plot in a new development off High Street, Henley.

Looking at settlements

3.4.9 In order to use settlements as a resource, it is necessary to look at them in detail. From the point of view of this guide, therefore, analysis of the existing environment is imperative in the generation of designs.

3.4.10 Stratford-on-Avon District has 113 Parishes, some with several villages or hamlets each. The District lies at the confluence of several character areas as identified in the Character Map of England: the Arden, Avon Valley, Feldon, Cotswolds and Ironstone Uplands.

3.4.11 As a consequence of its size and diversity, the District is far too large and varied to be summarised in a single - useful - document. The purpose of this guide is not, therefore, to provide a detailed account of characteristic forms. It is meant, instead, to provide a common means for looking for and identifying those forms and seeing them as a source for design. Good design will not come from a catalogue of characteristic details and materials. **A kit of parts with no instructions is of little use.**

3.4.12 Analysis fits into the overall recommended outline procedure set out previously:

- check the proposal is acceptable in policy terms;
- determine requirements to be accommodated on site as set out in the Local Plan and Planning Practice Notes;

- identify the character area within which the development is proposed;
- read the information regarding that area in this document and any relevant Village Design Statement, Conservation Area or other documents;
- **by visiting the site and using this guide, identify the specific characteristics that make up the site and the area in which the development is proposed;**
- discuss proposals with planning and conservation officers;
- demonstrate, in text and graphics, that the design submitted shares a sufficient number of those characteristics or justify their absence.

3.4.13 To facilitate the inclusion of analyses in the design process, **the following sections sets out both design principles and a sample analysis of a town within the District.** In addition, the results of analyses of selected settlements from the main character areas are shown to illustrate some of the features common to the areas.

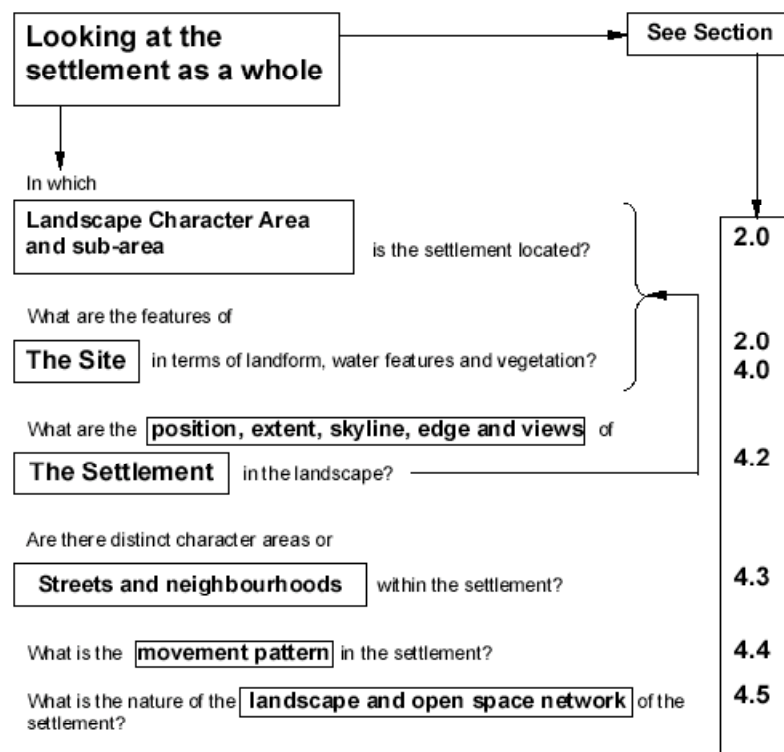

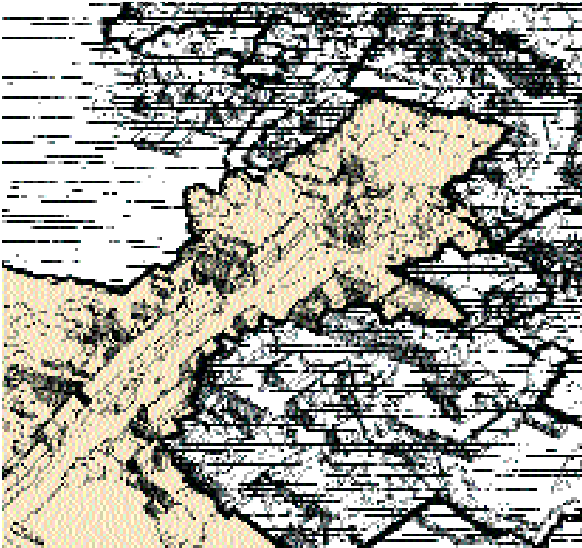

One street within the pattern of streets making up the settlement

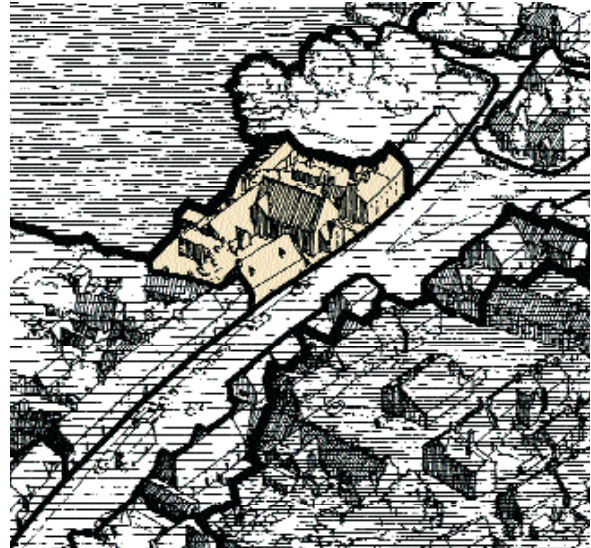

A series of plots of similar size making up part of the street

3.4.14 The following sections dealing with analysis and design principles are arranged by levels of scale. The purpose of the sample analysis is to point out the range of characteristics that might be used in taking existing settlements as a design resource

3.4.15 Any analysis done for a particular purpose should obviously focus on the scale or scales appropriate to that proposal. If the development is a large extension to a settlement involving a number of new streets, the

analysis should identify typical street/block patterns, typical highway designs, plot series and buildings as well as materials and details. Similarly, if a new plot is proposed, the analysis should identify characteristic plots. **It is important, however, to start with the settlement as a whole in order to identify the specific characteristics that make up the area in which the development is proposed.**

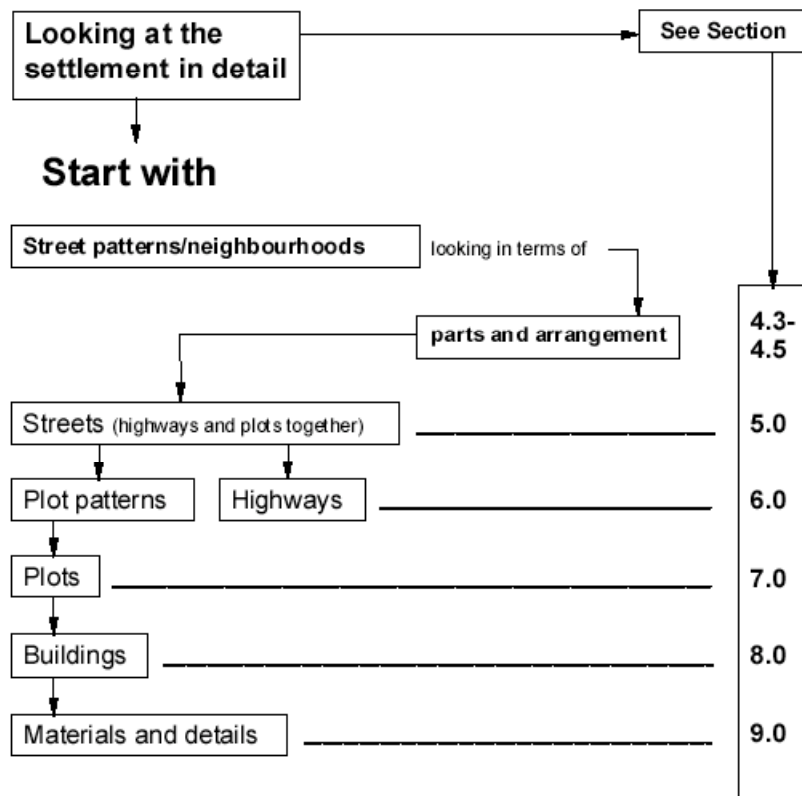

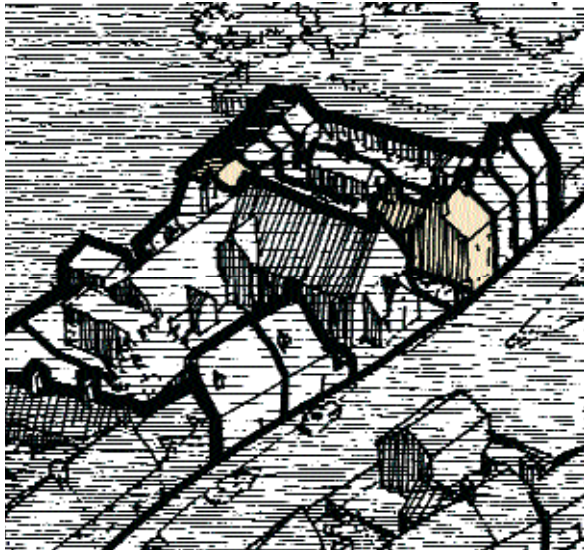

One plot within a series of plots

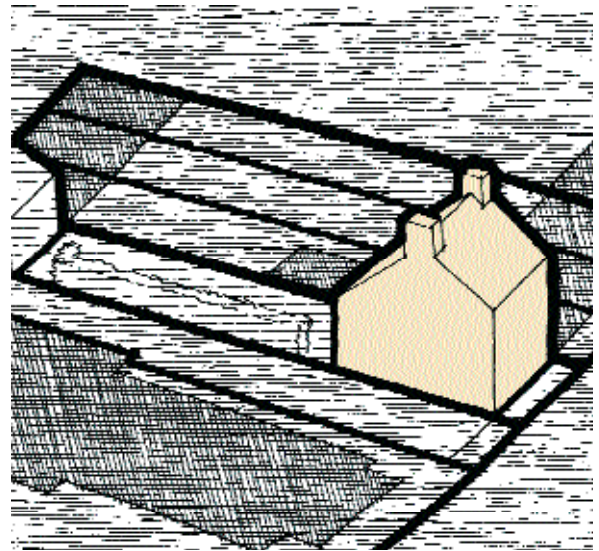

The main building in the arrangement of parts making up the plot

3.4.16 A central and fundamental principle of this guide is that new development should respond to its location within a settlement or surroundings as a whole and all appropriate levels of scale.

3.4.17 The starting point for designs on a particular site should be existing forms on sites with a similar relative position.

3.4.18 New development may present exceptions. In such cases, proposals must be accompanied by a statement that sets out the considerations taken into account, demonstrating why the exceptions are justified and the logic behind them.

3.4.19 The question to ask is, **what is the best form of development for a particular location? Which forms make the best use of the site's characteristic features?** Again, a great deal of information about the characteristic forms of settlements has already been gathered and can be found in Conservation Area documents and Village Design Statements. Such documents should be a starting point for analysis.

The diversity of forms

3.4.20 It is worth noting that the character of a settlement is not necessarily, and very seldom is, uniform. Places of a uniform character tend to be the exceptions. More often, a place can best be characterised by diversity, that is, by the range and mix of different elements. High Street in Henley-in-Arden, for example, has a clear identity but one that is characterised by a range of buildings in terms of type and period of origin. This is, of course, a matter of degree. Some places have a narrower range of variation than others. The degree of variety is in itself a feature of a place. Whatever the range, it is unlikely that an analysis of a settlement will result in a single characteristic type of house or street.

The similarity of position, orientation and relation to neighbours of the buildings gives Henley High Street a sense of unity despite the variety of building types



3.4.21 This raises a fundamental question about what should be considered 'characteristic' of an area. For the purposes of this guide, the answer relates back to the question of character and sustainability. The most characteristic local forms are those that respond to the location, making the best use of what exists, both natural and built, with local resources. This should be seen in opposition to erasing what exists and starting from scratch with imported resources. As with most things, this too is a matter of degree. Over time there has been a progressive tendency for design solutions and materials to be used over wider areas. From the dissemination of house designs in pattern books in the eighteenth century to the wider availability of materials such as Welsh slate and London brick in the nineteenth, house design has become more and more homogenised across England. As a result, there is a general correlation between the degree of 'localness' and date of origin. From about the fifteenth century (few examples of earlier buildings survive) to the present, 'older' generally means 'more local'. In most cases of analysis this tendency can be followed as a rule. As history well attests, however, this tendency is NOT an historical inevitability. **Newer does not necessarily mean less local and older does not necessarily mean more local. This is particularly relevant for new designs. A 'contemporary' design can be very local and a 'traditional' design can be very alien both in terms of the form and materials used.**

Innovation with a purpose

3.5.1 While design guides are often criticised for stifling creativity and innovation, any examination of the best designs shows they are responses to both specific, local issues and as well as general, wider concerns. Most successful innovations have a purpose. The aim of this guide is to promote successful, purposeful innovation.

3.5.2 If the success of an innovation is not to be a matter of chance, the design should be based on previous experience. The question is then, whose experience is most relevant? It is the premise of this guide that the most relevant experience for innovation in the design of the built environment is that embodied in the



Interior of the School of Farriery, Warwickshire College, Moreton Morrell. The form of the building - a traditional circular school with gallery - suits the purpose of instruction and integrates innovative use of materials and details into a well crafted whole

immediate environment itself. This is not to discount experience developed elsewhere nor experimentation but to say the starting point should be immediate experience.

3.5.3 In attempting to evaluate innovation, it is necessary to ask the question, why innovate? Innovation for its own sake is rarely satisfactory. More satisfying is innovation for a purpose. Ideally that purpose is not entirely personal but of wider significance. To that end, this guide seeks to encourage innovation that furthers the overall aim that designs should be local, sustainable and equitable. As far as possible, any innovation should seek to improve the quality and design of the public realm, its character and identity and overall health. Innovations should help to reduce the total energy cost and resource use of development and should seek to improve the multi-purpose use and adaptability of development.

Looking at the design of Settlements

4

- 4.1 Design and landscape
- 4.2 The settlement as a whole in the landscape
- 4.3 The internal arrangement of settlements
- 4.4 Movement and street patterns
- 4.5 Landscape and open space as a network



A view of Long Compton, Cotswold Fringe area, looking north over a field of ancient ridge and furrow

Design and landscape

4.1.1 While the aim of this document is to provide design guidance that takes account of the general character of large areas, the landscape as a whole is not itself the object of design. The common unit of development, which is to say, the development site, tends to be a plot or field (in part, as a whole or several taken together) rather than an area of countryside. **The concern must be, therefore, the cumulative effect of smaller scale changes on the countryside.** Development within settlements that changes the built up area and skyline of a village can have an effect on the landscape.

4.1.2 At this level, the following points should be determined in the design of new development.

- In which landscape character area is the development proposed and in which settlement within the area? [see chapter 2 and sections 4.2.1-4.2.2]
- What type of settlement is it in terms of its relationship to its site - its position relative to land forms, water features, other settlements and roads? [see sections 4.2.3-4.2.7]
- What is the extent of the built up area? [see sections 4.2.8-4.2.14]
- What is the skyline and edge character of the settlement, including landmarks visible from a distance? [see sections 4.2.16-4.2.21]
- What is the movement pattern within the settlement? [see sections 4.4.1-4.4.10]
- What is the nature of the landscape and open space network? [see sections 4.5.1-4.5.31]
- What is the arrangement of streets and neighbourhoods? [see sections 4.3.1-4.3.20 and 5]

The settlement as a whole in the landscape

4.2.1 It should be noted that within the context of the District Local Plan, the location of development is principally a matter of policy and secondarily a matter of design. Policy considerations will, therefore, take precedence over design considerations. Design principles should thus be followed within the bounds of what is acceptable in policy terms.

4.2.2 In terms of seeing settlements as a design resource, landscape character areas define a context for development in terms of the range of characteristic settlement types, and their various components at different levels of scale down to building types, details and materials. Each landscape character area has a more or less distinct range of typical forms, as set out in chapter 2 and as determined through looking at the settlements. The range provides for choice while the limits to the range help to define the character of the place. Within an area, there is a choice of forms but not an unlimited choice.

Types of settlement

4.2.3 Examination of settlements in the District suggests there are two basic types of development: **dispersed hamlets and farmsteads** on the one hand and **compact villages and towns** on the other.



The pattern of farmsteads in Ullenhall, Ancient Arden, Arden area

Farmsteads and hamlets

4.2.4 The character of historic farmsteads and hamlets is rooted in the association between the buildings and productive land. Dispersed settlements can thus be characterised in terms of the size and number of fields traditionally associated with a given building or group of buildings. This leads to a characteristic density of farmstead buildings within open countryside. The location of hamlets and farmsteads relative to land forms and water features tends to follow the same pattern as for compact settlements.

Compact villages and towns

Types by position

4.2.5 There are three types of compact settlement in terms of the position of the village or town relative to the principal features of land forms and water features:

- hilltop or ridgetop;
- hillside or hillside terrace;
- valley bottom, usually at the foot of the valley side and/or near a stream or river.

Each type has distinctive characteristics and so different principles apply to each.

4.2.6 As a general design principle, settlements should remain identifiable as a particular type.

- For dispersed settlements, the density and pattern of building relative to field area should be maintained.
- For compact settlements, topographic limits to development should be observed.
- Hilltop villages should, on the whole, remain above a given level.
- Hillside or terrace settlements should, on the whole, remain within upper and lower limits.
- Valley bottom settlements should, on the whole, remain below a given level.

4.2.7 The reasoning behind the original choice of position will likely have been based on a number of considerations. These may have included ground conditions (avoiding steep, wet or flood prone ground), distance to springs for fresh water, the presence of a ford or bridge, orientation to the sun (to increase light and warmth), protection from prevailing winds, the crossing of main routes etc. **Where the original reasons for the choice of position still apply they should be followed in judging the acceptability of development.**



Hilltop village, Ardens Grafton, Avon ridgelands, Avon Valley area



Hillside village, Sutton-under-Brailles, Fringe downlands, Cotswold Fringe area



Scarp slope valley bottom village, Radway, Scarp foot and slope, Cotswold Fringe area

Sample Analysis SHEET 1
 Kineton, Lias Uplands, Feldon area

The Settlement on its site

What is the position of the settlement in the landscape?

The village of Kineton, once a borough and site of a medieval market, lies at the crossroads of the Wellesbourne to Banbury road and a route connecting villages along the south-eastern edge of the Lias Uplands. The latter route runs parallel to the Clay Vale and Edge Hill scarp. Relative to surrounding towns such as Stratford, Southam, Shipston and Banbury, Kineton is small and relatively secluded. In relation to more immediately surrounding villages, Kineton is larger and more central.



Kineton on its site

The village sits on a rising site just on the edge of the Lias Uplands alongside the River Dene. It extends predominantly along an east-west axis parallel to the river and the Wellesbourne-Banbury Road. The river forms a barrier to growth to the south and the former railway line does the same to the north.

Examples of other settlements



Great Alne, a river valley bottom settlement, Alne and Arrow Valley Floors, Arden area



The Graftons, ridge top settlements, Avon Ridgeland, Avon Valley area



Harbury, a hilltop settlement, Lias Uplands, Feldon area

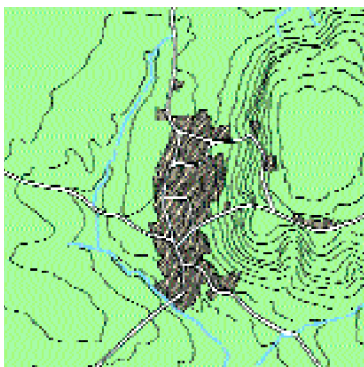

Priors Marston, a hillside settlement, Ironstone Uplands

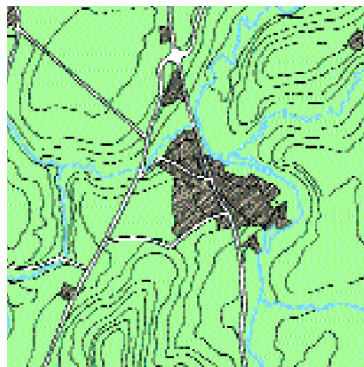

Tredington, a valley bottom/hillside hybrid, Upper Stour, Stour Valley area



Radway, centre left, scarp foot valley bottom settlement, scarp foot and slope, Cotswold Fringe area. Ratley, lower right, is a hillside type

Extent

4.2.8 Once established, a settlement will, generally, tend to expand along the main routes through it and on flatter ground not prone to flooding. The main route provides ready access and flatter ground is easier to build on. Secondly, development tends to extend off from main routes connecting to other routes forming a network. This suggests four further principles regarding position and built up area.

4.2.9 New development should extend along or gain access from the main routes serving the settlement.

4.2.10 Development should occur on flatter rather than steeper ground outside of flood plains.

4.2.11 Routes should connect to form a network.

4.2.12 If a connection is not possible at the time of development, the design should not close off the possibility of a future connection.

Patterns of growth

4.2.13 Examination of a number of settlements across the District reveals general patterns of growth.

- Dispersed hamlets and farmsteads tend to be located within an irregular pattern of lanes and an irregular plot pattern.
- Valley bottom settlements at the foot of the valley side tend to extend along the line of the valley, that is, following the contour lines. Secondly, they tend to extend out into the valley rather than up the slope.
- Valley bottom settlements adjacent to a river tend to sit on a terrace above the river level and extend along the line of the river or at right angles to it, depending on the direction of the main route. Settlements that contour a river tend, secondarily, to extend away from the river, more or less at right angles to the main route. With the exception of the larger towns such as Stratford and Southam, settlements tend to remain on one side of the river or stream.
- Hillside or hill terrace settlements tend to extend parallel to the contour lines of the hillside. Secondly they tend to extend downward along main routes.
- Hilltop or ridgetop settlements tend to extend along ridgelines and plateaux and secondarily downward along main routes.

4.2.14 New development should follow these tendencies in the respective types of settlement.

4.2.15 Even a quick look at actual settlements will show that there are many exceptions to these tendencies due to the need to balance the range of considerations.

Sample Analysis SHEET 2 Kineton

The Settlement: extent, edge character and views

What is the extent of the built up area?

In terms of extent, Kineton is something of a hybrid. It follows the general pattern of both a hill top and valley bottom settlement. Like a ridge top settlement it occupies a ridge and plateau and does not extend much below the 80 metre contour. All roads rise up to the central core of the village. Like a valley bottom settlement, it has extended along the main route, more or less parallel to the river. A secondary route runs perpendicular to the main route down toward the river.



View of Kineton from the west

What is the edge character and what are the important views?

The main edge character is planted and diffused, made up mainly by the river corridor, former railway line and large grounds or gardens. The tower of St. Peter's Church is the principal landmark of the village, visible from a distance on the northern and southern approaches to the village. There are views out to the north-west and south-west to farmland and parkland and to the south-east to Edge Hill.

Plan diagram of Kineton showing hard and soft edge elements



Skyline and views

4.2.16 The main issues affecting skyline are the relative height and arrangement of buildings and other large features. In most settlements the church with its spire or tower is the tallest landmark and is also often found on a rising site. Spires and towers are thus prominent landmarks and an important part of the landscape. Other features in settlements such as large public or private buildings, monuments and trees can play a similar part in the landscape.

4.2.17 New development should not block or obstruct views of important landmarks as seen from highways, footpaths, bridleways, public open spaces or other public areas either outside or within the settlement.

4.2.18 Views out toward the countryside from within a settlement (through gaps between buildings, down roads, streets and lanes and across open spaces) help to connect it to its surroundings and are an important way in which the settlement is rooted into the landscape.

4.2.19 New development should not block or obstruct views out as seen from highways, footpaths, bridleways, public open spaces or other public areas within the settlement (see also 4.5.5).

Edge character

4.2.20 The edge of a settlement is in many cases **soft**, mainly made up of trees and hedges or other planting. In other cases it is **hard**, made up of building walls or fences. The edge may be **diffused**, made up of large plots with detached houses, or **dense**, with terraced or other closely spaced buildings.

4.2.21 New development should maintain the most common traditional edge character of the area in which it sits.

4.2.22 The nature of planting in the different character areas varies significantly. Species used in buffer and edge planting should be appropriate to the character of the area in which it is proposed. For more detailed information please see Section 4.5 and the species lists for the relevant areas in Appendix D taken from the Warwickshire Landscapes Guidelines.



The internal arrangement of settlements

The pattern of streets and neighbourhoods

4.3.1 In general, villages and towns are not developed in an uncoordinated way, a building here and a house there with no clear relation between them. Even though they may appear haphazard and picturesque, nearly all settlements do have an underlying structure. Both planned and piecemeal development tend to occur in a similar basic pattern, usually a street or road lined on both sides by plots containing buildings. That generic arrangement is principally a matter of minimising expense and human effort. In order to get to a building you need a street or road. As roads and streets are relatively costly, it makes sense to have as many buildings as possible using the same road for access.

The street as a fundamental unit of development

4.3.2 The result has, in general, been buildings gaining access from a street and facing each other across it. This is true of both traditional and new development. The unit of 'carriageway with plots either side' is clearly seen in the older villages within the District. Equally there are many new developments that follow the same generic pattern.

4.3.3 When settlements grow, they tend to expand by the addition of plots along existing roads or by the addition of streets within or on the edges of the existing settlement. Growth thus involves either the filling in or creation of new streets.

4.3.4 For the purpose of this guidance, the term 'street' will refer to the highway AND the plots that line it either side, including public open spaces, taken together as a unit.

4.3.5 In order to integrate development within a settlement, the street should be taken as the fundamental unit of development. It should be seen as the starting point or context for design, whether the development involves several new streets or modifications to an existing one.

4.3.6 Development should be conceived in terms of this unit. Highways and access roads must be designed together with the plots, buildings and open spaces which they will serve. Likewise, buildings, plots and open spaces must be designed together with or taking account of the highways that serve them.



View and plan of Main Street, Ardens Grafton, Avon Valley area

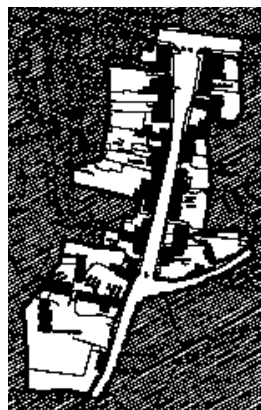

View and plan of Bridge Street, Kineton, Feldon area

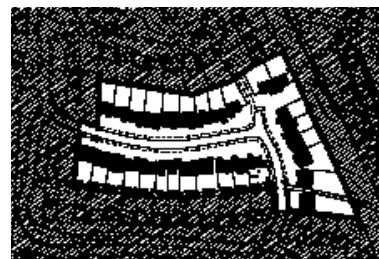

View and plan of St. Andrews Crescent, Stratford-upon-Avon, Avon Valley area

Integration of streets into a street network

4.3.7 In most cases, the growth of settlements has resulted in the creation of an interconnected network of streets and greens or squares lined by buildings.

4.3.8 A network of streets, as opposed to a tree arrangement with culs-de-sac along a main spine, has a number of advantages with respect to the goals of sustainable, local and equitable development. A network is 'permeable'. It offers a choice of relatively direct routes from any one point to another. It avoids the concentration of traffic (and so congestion) at the bottom of culs-de-sac and on main 'collector' roads. It maintains the continuity of a clearly legible public realm of streets, cyclepaths and footpaths. In contrast, tree systems tend to restrict choice, increase distance travelled, concentrate traffic onto a few routes that become congested or 'race tracks' and create monotonous and disorienting environments.

Street network in the centre of Kineton



Cul-de-sac development off the Warwick Road, Kineton

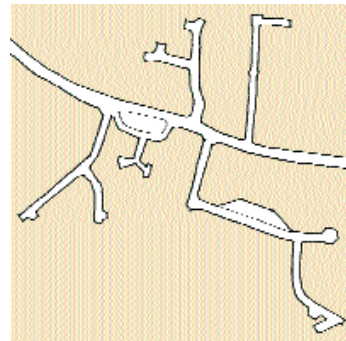

4.3.9 Any new development should reinforce or create a network of routes and allow for further connections. The connections may be selective, that is, allow for pedestrian or cycle but not vehicular movement.

4.3.10 There should be a logic to the network, that is, clear reasons for the location of a route.

4.3.11 Any particular route should normally lead to some destination or feature such as:

- another street;
- an actual connection out to the countryside by footpath, cycleway or track (or any combination of those);
- an open view out to the countryside (not simply a gap between houses but across public open space);
- a significant public open space with large stature trees;



A dead-end lane in Harbury, Felton area, that leads to the site of the former windmill and extends as a public footpath out into the countryside. The tall brick structure to the left is the base of the windmill

- a building that is distinct from the others along the street, (for example a large house or agricultural buildings).

The choice will depend on the context. Again, **look for local solutions first.**

4.3.12 The network of routes within a settlement should be a response to the physical characteristics of the site. See section 3.3 and in particular paragraph 3.3.7.

Large scale development and the term 'estate'

4.3.13 This guide is intended to apply equally to small scale development and what are commonly referred to as housing or industrial 'estates'. A word of caution is necessary, however, with the use of the term estate. Much of the development that has been conceived and built as estates is precisely the kind of development this guide is seeking to avoid. The concept of the estate tends to result in development that is inward looking, isolated from the settlement of which it is a part and uniform and often alien in detailing. The estate concept thus tends to become a barrier to integrating new development into a settlement and maintaining local distinctiveness. **All new development should be conceived of and appear as part of or an extension to an existing settlement, not a self-contained 'estate'. This emphasises the need for new development to make connections to and extend the existing movement network.**

Access, fronts and backs and orientation

4.3.14 With the generic structure of buildings facing each other across the street, the side of the building facing the public highway has generally been considered the 'public front'. It tends to be treated and used differently compared to the sides or backs. The distinction corresponds to that made between public and private behaviour. Some things are considered appropriate for the public context and others for the private. The most obvious expression of this in a building is keeping the front 'presentable' and tidy and leaving the back for 'messy' activities such as storage, services or washing. Likewise it is expressed in the greater investment in materials and details often found on the public front relative to the backs or sides. Orientation also has implications for security. Maintaining front-to-front and back-to-back relationships avoids exposure of the more vulnerable back and side boundaries of plots.

4.3.15 In order to maintain the distinction of public and private realms, to maintain security and the character of the street, fronts should face fronts across the highway.

4.3.16 By implication, backs should be set against backs when several streets run parallel or come together.

4.3.17 Responding to specific circumstances, in particular at corners (see 4.3.18), might require exceptions within the limits of a range, from most to least desirable relationships.

Plots separated by a path, drive, lane, street, square, green:

- front-to-front, most desirable
- side-to-side,
- front-to-side,
- front-to-back. least desirable

Plots sharing a boundary within a 'block':

- back-to-back,
- back-to-side, side-to-side.

These are general but not absolute rules. Applicants must demonstrate that they have exhausted the possibilities of maintaining front-to-front and back-to-back relationships before submitting alternatives.

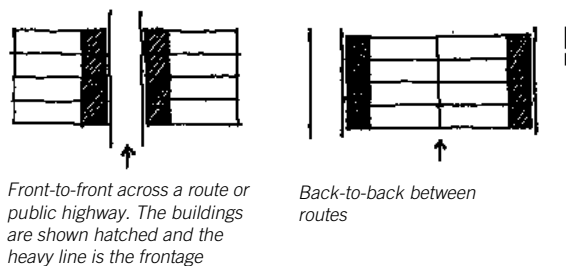

Street/block structure in Tredington, Stour Valley area



Front-to-front relationship



Back-to-back relationship

Turning corners

4.3.18 In a network of streets, the junction of two or more streets presents a special situation. For example, joining two idealised streets at right angles to form a T-junction gives rise to an 'overlap' of plots in the angles of the junction.

4.3.19 Seen separately, each ideal street includes a plot at the angle of the junction with a frontage on two streets. In order to fit the two streets together and complete the junction, some adjustment must be made in the area of overlap or corner zones. One solution is to create a 'corner plot' shared by both streets. The corner plots then potentially have access from, and public fronts onto, both streets. As detailed in the following section, corners present an opportunity. The transition from one character to another tends to occur around a corner.

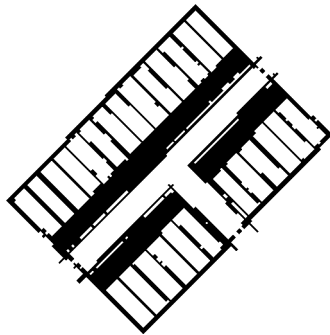

Ideal main street with a gap between plots to form T-junction.

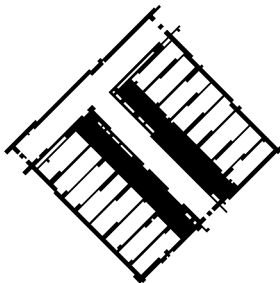

Ideal side street with plots running up to T-junction.

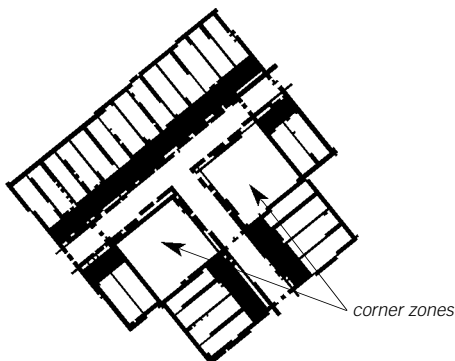

Main and side streets put together with corner zones at T-junction in which plots might front either street.

4.3.20 Corner plots thus give rise to several questions. If there is a concern to maintain the arrangement of fronts facing fronts across a street, which street should the corner plot face with its public front? If there is also a concern to maintain a hierarchy of streets, should the corner plot front on to the higher or lower weighted route? How is the transition made from one street to the other in terms of components and character? Should the building within the corner plot have two 'public' fronts, that is, two fronts with windows and appropriate detailing (even if only one front includes the door)? These questions emphasise that corners present an important design consideration, both as a challenge and an opportunity. There are many different solutions to the 'corner problem' and the particular solutions found in a settlement often contribute to its overall character.

4.3.20 The starting point for addressing the corner problem should be the range of solutions for similar situations found in the settlement in which the new development is to occur. Again, look for local solutions first.



A herringbone arrangement of plots as a solution to the corner problem



A herringbone arrangement of plots with a corner building

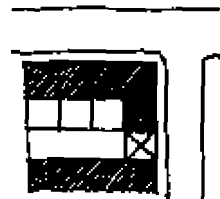

A courtyard arrangement



A wide frontage plot with side garden on the side street

Movement and street patterns

Different streets, different character

4.4.1 Close examination of traditional settlements reveals that many are composed of a number of different kinds of street. **Different streets have different character.** Many settlements have grown up along the main routes that lead from one place to another. Because they are through routes, they tend to be fairly wide. Also, in some cases such as Stratford, Alcester and Shipston, the towns were originally laid out to accommodate a market. In the latter cases both the street space for the market and the plots along it were deliberately designed using specific, often regular dimensions that are distinct from other streets. Thus, in general, a High Street is distinct from a side street or back lane. In this respect, settlements tend to have a hierarchy of routes from primary main streets to secondary and lower side streets. Differences in hierarchy and character tend to be associated with different positions in the settlement. Main streets tend to lead from one settlement to another or connect one central feature to another, side streets tend to connect one main street with another or end at the edge of the settlement.



The High Street is the central axis of Henley-in-Arden

4.4.3 Looking at a larger street network over a whole settlement, there is a general tendency for a change in the nature and character of streets moving away from the centre or central axis toward the periphery. In larger settlements, the distance from centre to edge is likely to be greater and there is likely to be a larger range of differences in character moving from the centre to the periphery or vice versa. To account for the range of differences, relative weight or values can be assigned to the streets. The central, main streets leading in and out of a settlement are primary routes, while side streets, moving away from the main routes, are secondary, tertiary etc. The range of different routes in any settlement may not easily fit into a simple numerical hierarchy. Any numerical or hierarchical value is, therefore, not as important as the differences in component elements and arrangement, which is to say, differences in character.

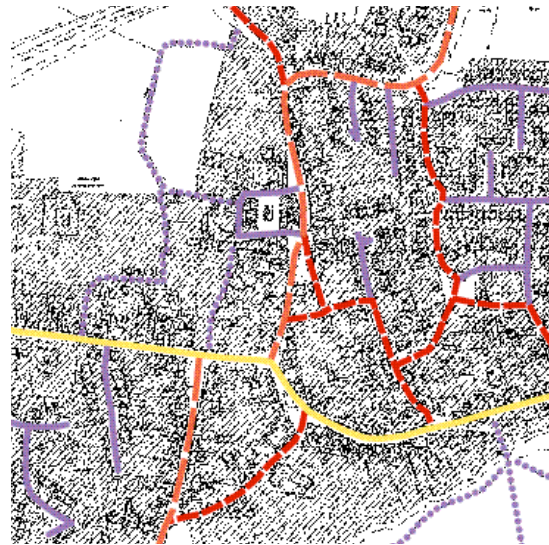

Hierarchy of routes. The main route is yellow, secondary orange, tertiary routes are red, quaternary violet and footpaths dotted violet

Centre and periphery

4.4.2 In general, the difference between main and side streets corresponds to the difference between the centre and the periphery. On a purely geographical basis, all settlements have a middle and an edge. In terms of movement, the centre is generally the place that the most people can reach in the least time and with the least effort. For that reason the centre tends to be the busiest and is usually the place where shops, offices and pubs are located. In general, the main street forms the central axis of a settlement.



Banbury Street, Kington, a main route, in yellow and Mill Street, a side street, in red.



Banbury Street is wide with a grass verge and houses set back from the footpath.



Mill Street is much narrower with houses close to the footpath and carriageway.

4.4.4 New development, of whatever scale, will necessarily occupy a position within a hierarchy of streets. Whether at the centre, periphery or anywhere in between, that position will present a specific context in terms of the character of the streets and the differences between them.

4.4.5 Position in a hierarchy of streets is a fundamental consideration in design.

Sample Analysis SHEET 3 Kineton

Settlements: Street patterns

What is the range of different streets and their arrangement?

Following the general tendency of traditional settlements, the street is the basic unit of development in Kineton. The street pattern is predominantly one of through streets that fit together to form a network. There are four 'main' streets each with a different character, Warwick Road, Bridge Street, Banbury Street and Southam Street. Connecting these are smaller narrow traditional lanes: including Mill Lane and Manor Lane as well as modern 'estate' roads. There are also some areas with culs-de-sac and loop roads that form dead ends.

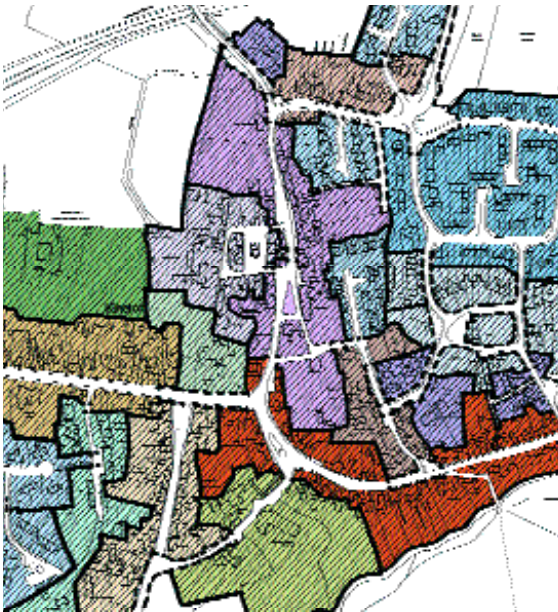

Component streets

Though the pattern of streets in Kineton forms a network, virtually all the junctions are T junctions. Thus, even though Kineton is a 'crossroads' village, it might better be called a 'staggered' or 'skewed' crossroads. The four main routes converge on a central 'block'. Because the routes forming the block are of different weight and character, however, the block has different character on different sides. The four main routes are the widest and are well defined by buildings. The tertiary routes are narrower but less continuously defined by buildings. They tend to connect one primary or secondary route with another. Most of the culs-de-sac connect to the Warwick Road and the loops between Banbury Street and Southam Street.

Hierarchy and character

4.4.6 The differences in character corresponding to differences in position can be seen at a number of different levels. Often the main street was an existing road and as a result the street winds and varies in width. In some villages the main route has a wide grass verge while in towns there are often wide footways. Streets at the centre tend to have more small plots - often deep with narrow frontages - and building coverage is high. Generally the buildings are older and tend to be set at the front of the plot (the back of the footway), usually of two and sometimes three storeys.

4.4.7 Turning off the main street, the side streets tend to have narrower carriageways, with or without footways. The geometry of streets tends to be more formal and regular. Plots are on average larger, building coverage lower with newer buildings. In larger settlements the periphery tends to include areas of housing mixed with, for example, larger farm complexes, schools, markets or industrial estates. Such generalisations illustrate the



Another aspect contributing to the character of streets is the definition of spaces as part of a landscape and open space network.

See section 4.5

point that different streets should have different character. While there are some common differences, each settlement is unique in terms of the specific details of each distinct street.

4.4.8 New development should reinforce or complement the existing hierarchy in terms of range and character.

Thus, in the process of design, an essential question to ask at an early stage is: what position does the site occupy relative to existing routes and where in a hierarchy of routes will any new streets fit?

4.4.9 In the case of large scale development involving the creation of new streets, the development should be recognisable as an extension of the existing network in terms of hierarchy.

- New streets must maintain a clear and appropriate relation to the existing street network in terms of weighting and character.
- Within the site there should be a clear distinction between primary, secondary and any other lower weighted routes appropriate to the size of the site and its position relative to the surrounding street network.

4.4.10 See chapter 5.0 for further principles concerning streets.

Landscape and open space as a network

4.5.1 The combination of streets, squares and greens making up a settlement generally forms a network of public spaces defined by the public fronts of plots and buildings as well as landscape features. The resulting pattern of spaces, including other public rights of way such as footpaths and bridleways, is an important aspect of a settlement. The experience of walking, driving, riding or cycling from one space to another is the basis for people's perception of the settlement. Moving through the sequence of spaces is the way people get to know and recognise its character and identity. A trip from one point to another is not just a journey from A to B. The landscape and open space network - defined by all its component parts - provides a series of cues and features that make it unique. The terms commonly used to describe or define the landscape and open space network include paths, edges, landmarks, gateways, nodes, central spaces, crossings, views and vistas. Spaces in the network tend to be defined by buildings and/or plants and described in terms such as large/small, open/enclosed, narrow/wide, long/short, straight/curved, central/peripheral.



Ardens Grafton, Avon Valley area. A view out over the countryside accentuated by a tree in the middle ground.



Harbury, Feldon area. The view down Chapel Street is terminated by a magnificent beech tree.



Far too often views within new developments are inappropriately terminated by garages.

4.5.2 The position of a site within, and its contribution to, the pattern of spaces, defining buildings and boundaries and landscape features is an important consideration for design.

4.5.3 New development should maintain and extend the landscape and open space network of an existing settlement by taking best advantage of existing features and creating new features appropriate to the location including:

- routeways of different kinds,
- edges or boundaries between distinct areas,
- landmarks,
- gateways,
- crossings,
- central spaces,
- views.

4.5.4 The boundaries, size and sequence of open spaces, including highways and footpaths etc., created by new development should extend and enhance the character of the landscape and open space network of an existing settlement.

4.5.5 Views along streets are particularly important in the integration of the landscape and open space network. In many traditional settlements, for example, there is a visual link between landmarks such as churches, other major buildings or trees and the main streets. Landmarks tend to mark the end of the vista down the street. Equally, views out of the settlement often incorporate the open countryside as a visual feature.

4.5.6 New development should, wherever possible, incorporate surrounding landmarks or open countryside as part of the landscape and open space network of the settlement (see also 4.2.18).

4.5.7 Views within new development should be adequately terminated.

4.5.8 The terminal feature should be visually appropriate, that is, a public building, major landscape feature, mature tree or, for example, the public front of a building, rather than a blind gable end or a garage. The feature should be strong enough visually to catch the eye and stand up to scrutiny.

The importance of landscape and planting

4.5.9 It cannot be emphasised enough that both hard and soft landscape features should be an integral part of initial design ideas. Submission of landscape information at the outset should help to avoid change at later stages with regard to the integration of the design into the existing landscape network as well as its effect on highway safety, sewers and other underground services.

4.5.10 Hard and soft landscape features must be conceived of as an integral part of designs for new development AND as an integral part of the wider landscape and open space network.

4.5.11 Concept information regarding landscape proposals should be submitted as early as possible in the application process, including indications of arrangement within the overall landscape and openspace network, arrangement within the site showing space requirements and general indications for species.

4.5.12 In certain circumstances District Local Plan policies require new development to include a percentage of public open space. For details of these requirements and requirements for the maintenance of the space, please refer to the current version of the District Local Plan. The location and character of open spaces and landscape features is a question of design and should be based on the principles found in this guide, in particular the analysis of the settlement in which development is proposed. For an assessment of the importance and character of opens spaces within selected settlements, please also refer to the relevant Conservation Area documents and Village Design Statements.

4.5.13 For further details regarding landscape design, please refer to sections 6.2, 7.4 and Appendix D of this document and to the advisory leaflet 'Landscape Design' available from the Planning Department.

The uses of landscape

4.5.14 Areas of planting should not be viewed solely as a visual amenity but a resource with a number of potential benefits. A multi-purpose landscape will be more robust and better serve to integrate new development into its surroundings.

4.5.15 Landscape features should be designed as multi-purpose elements within the broader network, serving where possible as:

- public open space,
- a visual amenity,
- a buffer against temperature extremes,
- a wildlife habitat,
- a land drainage feature.

Maintenance

4.5.16 The ongoing maintenance of plant material is crucial to its effectiveness as part of new development. It is therefore essential that the responsibility for maintenance of planting in new development is clearly established prior to the issue of planning consent.

4.5.17 Ideally, structure planting, corridor, screen and street tree planting should be within land normally maintained by the Parish, District or County Councils or by some other public body or trust.

4.5.18 A financial contribution for the maintenance is normally expected in the form of a commuted sum.

Edge, screen and corridor planting

4.5.19 As noted in sections 4.2.18-4.2.21 above, the edge character of a settlement is a fundamental aspect of its character. In cases where the treatment is soft, the principal constituent of the edge is most often hedges with hedgerow trees and/or less formal screen planting.

4.5.20 To be effective, the space for this edge and screen planting should be a minimum of 5 metres wide.

4.5.21 Buffer and corridor planting associated with major roads, railway lines or other features as well as ecological or wildlife corridors should be a minimum of 16 metres wide. The corridors should be sufficient in length to connect other major landscape features.

Specifications for such planting are included in Appendix E.

4.5.22 While often appropriate as an edge treatment, screening and hiding should not be the principal approach to dealing with the boundaries between new development and other areas within a settlement.

Choice of species

4.5.23 Particularly in a rural location, the impact of planting on the character of a settlement can be very significant. For that reason, the choice of species for planting proposals is extremely important.

4.5.24 Native and long established naturalised species should be the dominant and most common species in any proposal. Ideally, plant material of local provenance should be used, that is, material grown from local seed in local nurseries.

4.5.25 As the *Warwickshire Landscapes Guidelines* make clear, the range of species found in the different character areas within the District is not uniform. Different species are found in different areas. The Landscapes Guidelines include species lists for the different areas and indications for different specific locations such as woodlands, hedgerows and riversides. The lists are included in this guide as Appendix D.

4.5.26 Use the appropriate species for a given landscape character area and location as set out in Appendix D

Large stature trees

4.5.27 *Large stature trees* are trees of certain species that naturally grow to a large size such as oak, beech or lime. It is important to distinguish a large stature tree from a large *specimen*. A large specimen is, generally, a tree of any species that is planted when it is older and has reached a larger size (regardless of how large it might get). Large stature trees like oak and lime often form an important part of the landscape and open space network of a settlement. Such trees are often located at the end of vistas, on the outside of a bend in a street, along the street as street trees or in greens. **It should be noted that whatever species is selected, there are distinct advantages in planting young specimens. Young specimens are better able to adapt to particular conditions, will grow faster and taller and will be more likely to survive than older, larger specimens.**

4.5.28 In the appropriate circumstances, large stature trees should be included in new development as focal points, street trees or part of structure planting.

4.5.29 The most suitable location will depend on the character of the settlement and the specific circumstances. Choice of location should be based on an analysis of the settlement.

Great Wolford, Cotswold Fringe Area. A mature horse chestnut terminates a view. Situated on the outside of a bend, it is visible from two directions.



4.5.30 When large stature trees are included in development, it is essential that the foundations of surrounding buildings are built to a sufficient specification to withstand the conditions that result from the presence of roots.

Suggested species for large stature trees

4.5.31 The following is a list of large stature trees that may be appropriate within the district, depending on the landscape character area and specific location in which the development is proposed.

•Horse Chestnut	<i>Aesculus hippocastanum</i>
•Maple	<i>Acer campestre</i>
•Beech	<i>Fagus sylvatica</i>
•Ash	<i>Fraxinus excelsior</i>
•Oak	<i>Quercus robur, petraea</i>
•Pine	<i>Pinus spp.</i>
•Willow	<i>Salix spp.</i>
•Yew	<i>Taxus baccata</i>
•Lime	<i>Tilia spp.</i>

In some specific situations, the following may be appropriate.

•Cedar	<i>Cedrus atlantica, deodara</i> -
	• limited use in large gardens within settlements
•Plane	<i>Platanus x hispanica (acerifolia, hybrida)</i> -
	• for urban areas
•Locust	<i>Robinia pseudoacacia</i> -
	• for urban areas

Other species may be acceptable.

Examples of route hierarchies, component streets and openspace networks from other settlements

Welford-on-Avon, Avon Valley area

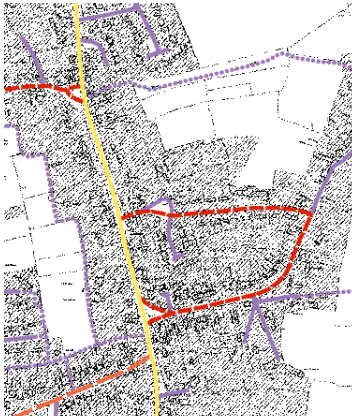

Welford-on-Avon - Hierarchy of routes

Stretton-on-Fosse, Cotswold Fringe area

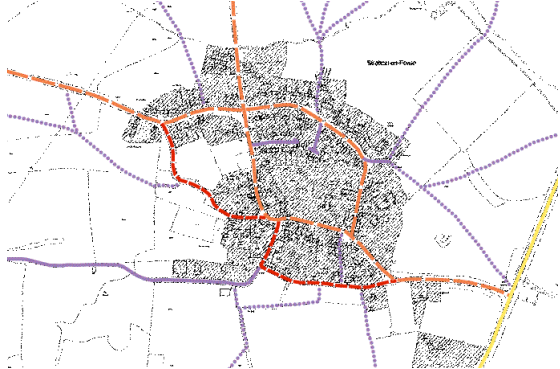

Stretton-on-Fosse - Hierarchy of routes

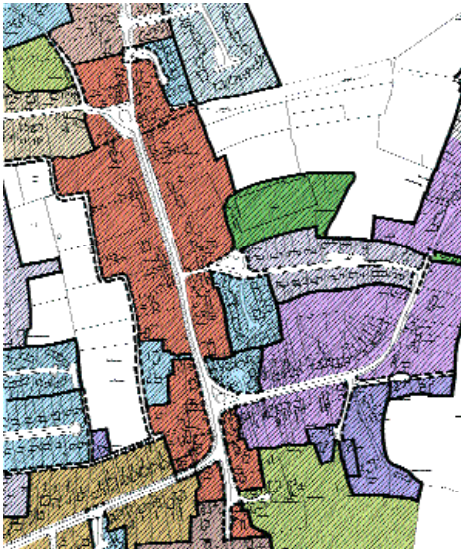

Welford-on-Avon -Component streets

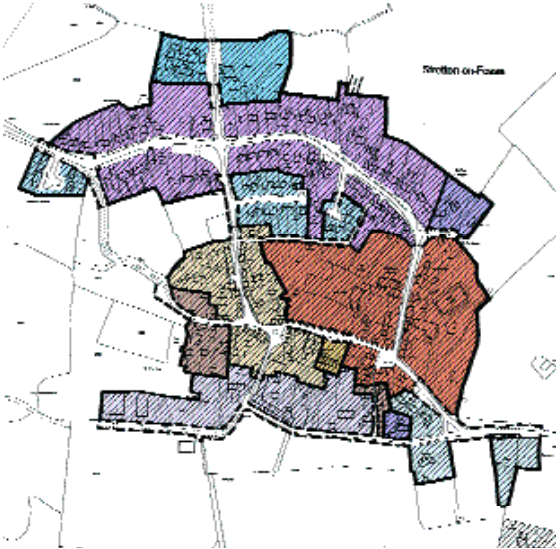

Stretton-on-Fosse - Component streets



Welford-on-Avon - Landscape and openspace network



Stretton-on-Fosse - Landscape and openspace network

Sample Analysis SHEET 4 Kineton

Streets

What makes a particular street different from others? What is its position?

The analysis will take Banbury Street as an example. The street is a main route into the village that connects to the main crossroads with the Warwick Road and Southam Street. Though a main route, it runs for a significant length along the southern edge of the village, parallel to the River Dene. There are three junctions, one with the secondary route, Manor Lane, the others with tertiary routes, Mill Street and Mill Lane. The latter gives access to the development to the north and connect through to Southam Street. There is also a loop further to the east giving access to the High School as well as a footpath connection to the south leading to the allotment gardens and a footpath leading north toward the old mill. The stretch from Mill Street west to the junction with Warwick Road contains most of the shops, pubs and businesses in the village.



Banbury Street, Kineton

What is the shape and size of the street?

As a main route, Banbury Street is quite long. In overall form, it has two sections, a straight length to just past Mill Street and a curving section from there to the junction with Warwick Road. Including the plots either side served by the street, the width varies from about 40 metres to about 120 metres. The southern boundary of the street (the backs of the plots) runs along the River Dene and so takes the shape of the river. The northern boundary is shared with plots of development to the north and runs in a broken but geometric line more or less parallel to the carriageway. It is also noticeable that the street pinches down toward the carriageway at the junctions with Mill Street and Manor Lane.



Banbury Street
within the village

What is the range of parts and what is their internal arrangement?

The main components of Banbury Street, Kineton are plot series, including the allotment gardens, and the highway. The highway includes the carriageway, verges, footpaths and, at the top between the junctions with Manor Lane and Warwick Road, an oblong island of grass with a monument. The overall arrangement is highway flanked either side by plot series or allotments in more or less parallel strips. There are thus two main plots series with a single highway between them. Access to the plot series is from the highway so the fronts of the plot series face each other across the carriageway.

There are several different kinds of plot series along Banbury Street. To the east, the allotments occupy a relatively narrow stretch between the carriageway and the River Dene. Moving west along the southern side is a regular plot series of moderately wide and quite deep plots. Beyond, near the junction with Manor Lane there is a distinct series with small nearly square plots. The north side is lined with a more or less irregular plot series.

- 5.1 The street as a unit character
- 5.2 Variation of character and position
- 5.3 The extent of the street
- 5.4 The parts and arrangement of a street
- 5.5 Visual integration within streets

The street as a unit of character

5.1.1 As set out in section 4.3, the basic arrangement of a street or road lined on both sides by plots containing buildings is a common feature of virtually all settlements in the district. It was also noted in section 4.4 that within settlements in the District, **different streets have different character**. Therefore, in the same way that the street, conceived as ‘highway with plots either side’, is taken as a fundamental unit of development, it is also taken as the fundamental unit of character.

5.1.2 In order to integrate development within a settlement, the street should be taken as the fundamental unit of character or a character area within a settlement. The street should be seen as the starting point or context for design, whether the development involves several streets or modifications to an existing one.

Variation of character and position

5.2.1 The variation in character noted above and in section 4.4 tends to be a response to the position of the street on the site, within the hierarchy of streets making up the network and within the landscape and open space network.

5.2.2 In new development involving the creation of one or more streets, the character of each street should be an appropriate response to the following:

- its position on the site, including such features as topography, proximity to rivers or other bodies of water, trees and other landscape features, the path of the sun, prevailing winds, landmarks both outside and within the site (see also paragraphs 3.2.5 and 3.3.7);
- its position within the hierarchy of routes making up the settlement;
- its position within the landscape and open space network;

Site levels

5.2.3 A specific and extremely important implication of the above principles involves the issue of site levels.

5.2.4 Keeping in mind the street should be seen as the unit of development, the relative levels of carriageways and the buildings they serve should be considered a central feature of the unit.

5.2.5 In particular, sites should not be filled and lifted solely in order to achieve adequate drainage falls.

5.2.6 In order to evaluate schemes in this regard, there are two main points that must be made clear in any proposal. One is the absolute change in levels and the impact of that change on surrounding physical features, properties and the village as a whole. The other main point to be made clear is the relative levels of proposed houses and the streets serving them.

5.2.7 It is essential that level information is submitted as early as possible in the application process.

- Existing and proposed level information must be submitted together on the same plan.
- Proposed levels should include, as a minimum, finished floor levels of buildings, cover levels of access holes and other surface equipment and street levels.
- The submitted information should clearly show the relative height of finished floor levels and the levels of the nearest adjacent carriageways or pavements.
- If the difference is sufficient to require treatment to retain the earth, details of the proposed treatment must be provided.
- On large sites, proposed contour information should be included in addition to spot levels.

The extent of the street

5.3.1 Examination of settlements in the District shows that, along with variation of character from street to street, the extent of a particular street of the same character varies with position. That is, main streets tend to be longer and the extent of the character area is larger relative to side streets.

5.3.2 In new development involving the creation of one or more streets, the extent or size of a street, as a character area should be appropriate to the position of the street within the hierarchy.

- Primary routes should normally be more extensive.
- Secondary and lower weighted routes should normally be less extensive.

Examples of streets from other settlements

Welford-on-Avon, Avon Valley area

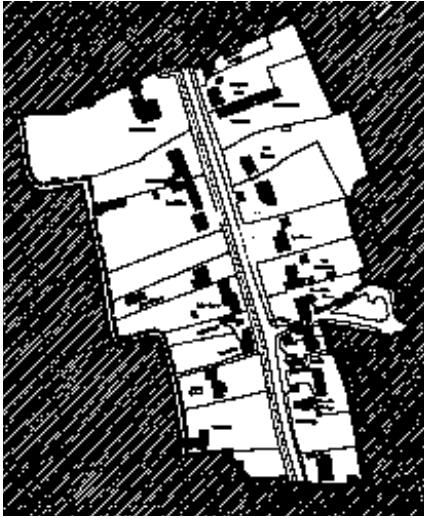

High Street, a primary route with a relatively wide highway and plot series of large rectangular plots.

Stretton-on-Fosse, Cotswold Fringe area

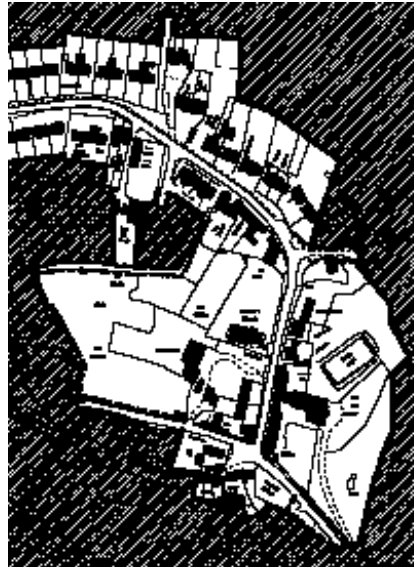

A primary route within Stretton-on-Fosse divided into two distinct parts, one with plot series of small regular plots, the other with mixed series with different plot sizes and shapes.

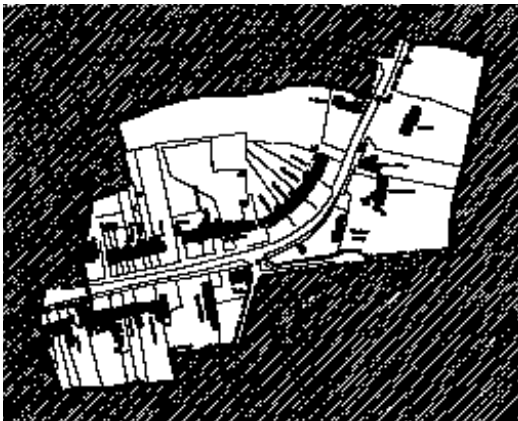

Chapel Street, a secondary route with a narrow highway and a variety of plot series in terms of plot size and shape.



Belcony, a primary route including an irregular highway and a combination of linear and courtyard plot series.

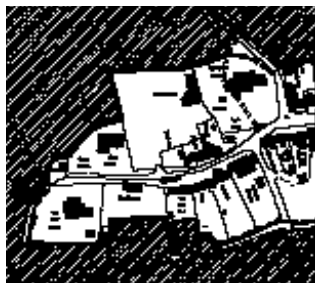

Boat Lane, a cul-de-sac terminating in a footpath leading into the countryside. The plot series are more or less regular but with a mixture of plot sizes



Carson Close, a cul-de-sac with a 'standard' highway and regular plot series. Note the shorter plots by the corner in response to the plot fronting the main street.

The parts and arrangement of a street

- 5.4.1** The structure of a street as set out in sections 4.3 and 5.1 includes two general components, a highway and plot series. A plot series is a row of plots usually forming a continuous frontage along a public highway. The plots making up the series are often of similar size and shape though analysis shows there are frequently variations depending on specific circumstances. See section 6.1 for further discussions of plot series.
- 5.4.2** The highway is generally composed of a carriageway and, in many cases, one or two footways or verges. Various other components are found in particular situations as discussed in section 6.2.
- 5.4.3** All new development should follow the general pattern of highway flanked by plot series either side as a basic starting point for design.
- 5.4.4** The design of streets should vary to suit their position on the site, within the hierarchy of routes, the character areas and the landscape and open space network making up the settlement.
- 5.4.5** In the case of a main street with a larger extent, there should be some variation along the street from centre to periphery.
- 5.4.6** Variations in the arrangement of streets might include:
- the position of any proposed open spaces and squares within a street and relative to junctions with other streets;
 - the shape ('geometry'), size and component parts of the streets and open spaces
 - the shape, size and component parts of the plot series
- 5.4.7** The way in which streets vary should be based on variations characteristic of similar circumstances in the settlement in which the development takes place.
- 5.4.8** New designs to meet new requirements should be adaptations of existing arrangements. Particular attention should be paid to characteristic associations between *position* and the *geometry and arrangement of parts*.

Sample Analysis SHEET 5 Kineton

Streets

Are there typical associations between location and the design of highways, open spaces and plot series?

The open spaces or 'squares' in Kineton tend to be widenings of primary or secondary street spaces. Examples include Banbury Street, the top of Bridge Street and the lower section of Southam Street. Market Square is an exception both because it is more regular and part of a tertiary route.



The main open spaces are, in general, associated with junctions and tend to be triangular or rectangular in shape. Thus the top of Bridge Street splays to form a triangle at the junction with Warwick Road; the bend in Banbury Street near the junction with Manor Lane widens into a triangular form; the rectangular space near the junction of Mill Street and Southam Street includes a grassed triangle. The Market Square is a further example of a rectangular space though with a building in the middle.

Aside from the primary and secondary routes, there are very few long, straight streets. The tertiary routes tend to be short or include a sharp bend. Warwick Road and sections of Banbury Street are the only long, dead straight streets. Most others have very gradual bends or a distinct, more or less ninety degree bend.

The routes into the settlement tend to include areas of planting so that the transition from countryside to settlement is gradual as opposed to distinct and clearly articulated. There is not, however, a distinct difference along the streets moving from centre to edge. The principal difference is that the set-back of houses tends to increase moving out from the centre. Houses on the edge tend to be set back somewhat further.

There are differences in plot series depending on where they are found within the street. At junctions and when there is some other physical boundary or constraint the plots tend to be shallower.

Visual integration within streets

5.5.1 A common complaint made against much contemporary development involving new roads is that highway geometry seems to take precedence over all other considerations in the design of new development. Part of the problem is the tendency for the roads with their turning heads and parking areas to be conceived as mono-functional elements, solely for the use of motor cars. Whether this is actually the case in the design process or not, the issue is that the streets appear fragmented and there is little integration of the highway and the plots and houses either side. Rather, the highway seems to meander between arbitrarily placed houses giving rise to a sense of disorder and disorientation.

A straight row of rectangular plots staggered to accommodate a curve. The road appears isolated and unrelated to the houses.

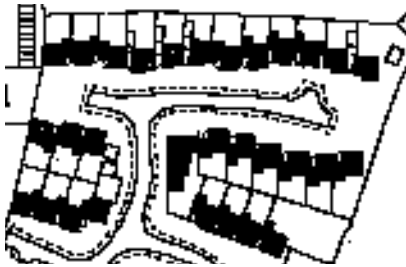

5.5.2 A common example of this problem is the combination of a curving road and rectangular plots laid out parallel to each other. To accommodate the curve, the plots are staggered in a saw-tooth arrangement. The general sense of fragmentation is reinforced by the fact that there is little continuity of elements along the highway. The different elements do not work with each other to reinforce the line of the road. In contrast, the common solution to alignment along a curve in traditional settlements is to splay the plots to form a continuous line following the curve of the road. The various elements of the street tend to form an integrated whole.

View and plan of Banbury Street, Kineton. Façades, eaves and roof ridges are parallel to and reinforce the line of the carriageway.



5.5.3 In many examples of streets in the District, the ridge line of the buildings, the front facade as well as the front boundary feature tend to run more or less parallel to the edge of the carriageway. One element reinforces the other to create a coherent entity. The elements hang

together as an identifiable set of interlocking parts. A footway or verge, for example, can be seen as a part of both the carriageway **and** the plots that front it. Similarly, plot frontages such as walls or hedges can be seen as part of both the plot and highway. When this is achieved, the carriageway is subservient to the design and character of the whole. Its specific role is not limited to accommodating cars. This is not to exclude variation but to suggest that the variation ought to occur within an acceptable range with elements that do maintain continuity.

5.5.4 On another front, the arrangement of houses overlooking the street is generally agreed to lead to safer streets because occupants can observe what goes on in the public realm with relative ease and also see when people have passed from the public into the private realm. Also, as recent research suggests, this arrangement leads to better security because the flow of people along the street can also observe what is happening on the frontage of a house.

5.5.5 Highways and the plot series and open spaces they serve should be seen as an interlocking arrangement of components not a collection of objects in proximity. The carriageway, footways and verges should all serve to reinforce the character of the whole not merely exist as mono-functional elements within it.



The highway defined by the shared element of plot frontages

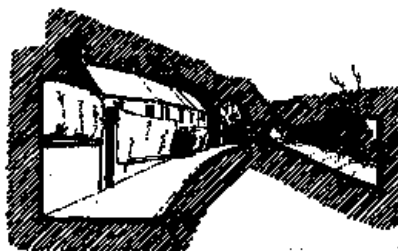

The shared element of footway and verge as an extension of the plot series

5.5.6 Speed control bends and turning heads should in particular be clearly integrated with the plot series and buildings around them in order to avoid the appearance of a mono-functional element placed arbitrarily.

5.5.7 Each component part should appear as a distinct element and at the same time to belong together with the others. Footpaths, verges, and other elements of the highway including planting areas and large stature trees should appear as a positive extension of both the plot series and highway.

5.5.8 See chapter 6.0 for further principles concerning highways, open space and plot series.

Looking at the design of Highways, open spaces and plot series

6

- 6.1 The components
- 6.2 Highways
 - Other sources of guidance
 - Highways and open spaces within the street
 - Design and use
 - Carriageways, footways and islands
- 6.3 Plot series

The components of streets

6.1.1 The various component parts of the street each present a range of considerations for design. The previous section dealt with the way the parts go together. This section deals with the design of each part as an element in itself, first highways and open spaces, then plot series.

Highways

Other sources of guidance

6.2.1 The design of highways is subject to advice and guidance at both the national and county levels. The principal technical source for national advice on highway design for residential areas is *Design Bulletin 32 Residential roads and footpaths* (1977, 2nd edition 1992). This has recently been updated by *Places, Streets and Movement: A companion to Design Bulletin 32* (1998). Both are available through branches of Her Majesty's Stationary Office (HMSO) and the Department of the Environment, Transport and the Regions (Publications Sale Centre, Unit 8 Goldthorpe Industrial Estate, Goldthorpe, Rotherham S63 9BL). Within Stratford-on-Avon District, additional guidance is provided by Warwickshire County Council's *Roads and Transport for Developments: The Warwickshire Guide 2000* (forthcoming) available from the County Council Office and Committee Services (Department of Planning Transport and Economic Strategy, Shire Hall, Warwick CV34 4SX, telephone 01926. 412395).

6.2.2 The information in these documents should form the basis for the design of new highways. As stated in *Places, Streets and Movement* (page 12), 'local highway standards are not statutory; nor are DB32 and the many local design guides which reflect and interpret its precepts. However, all of these documents are vital to the design process because of the guidance they provide on the overall layout and design of residential roads and footpaths'. **This guide aims to explain how the general advice is to be interpreted and applied at the local level in order to take account of the character of each area.**

6.2.3 In the design of new highways the most recent guidance should be consulted first.

6.2.4 To aid in the interpretation of the guidance and in order to achieve a high standard of integrated design, it is essential that applicants contact a District Council Planning Officer and County Council Highways Officer as early as possible in the design process to clarify questions of transport and highway design.

This is particularly important with large scale development where provisions for public transport will normally need to be considered.

Highways and open spaces within the street

6.2.5 As set out in sections 4.3 and 5, development should be conceived and designed in terms of the street as a unit with the plots it serves. The street in turn contributes to a hierarchy of routes and landscape and open space network.

6.2.6 The overall design of development should not be led or determined by highway design. The alignment and details of the carriageway and footways should be designed together with the open spaces, plots and houses they serve.

6.2.7 In many cases open spaces are incorporated within or closely associated with the highway. In those cases the principles applying to highways in this and other sections also apply to open spaces.

6.2.8 The basic question applying to design, 'how can the best design be achieved within the bounds of what is acceptable in other terms.' is particularly important in the case of highway design.

6.2.9 The starting point for designs should be the geometry and arrangement of existing roads, streets, lanes and associated open spaces in the area where development is to occur, not standard dimensions. Existing types of highway and open space should be adapted with as little change as necessary to make them acceptable in the terms of current optimum standards.

6.2.10 Depending on the circumstances, carriageway and footway or verge widths should vary to suit the space between plot series either side of the highway - which in turn should not be uniform. Variations in width should not be arbitrary or too small in scale but associated with or a response to existing or proposed features.

6.2.11 It is generally expected that footways and verges should be included in the highway in order to accommodate public utilities. Guidance on the location and dimensions of service strips is found in *Roads and Transport for Developments: The Warwickshire Guide 2000*. **There should be scope, however, for some variation in location and dimensions depending on the specific circumstances. To this end, applicants are advised that it may be possible to negotiate with the statutory undertakers in order to determine the actual requirements in a particular case - which may differ from the standard locations and dimensions.**



Pinch point, Shipston-on-Stour, Stour Valley area

6.2.12 In many parts of villages and towns in the District the highways are made up of a carriageway only, without any footways. **In areas where this type of highway is prevalent, the most appropriate form of new road is likely to be a shared surface as defined in Design Bulletin 32.** Existing types should serve as the basis for new designs in terms of geometry, arrangement and materials.

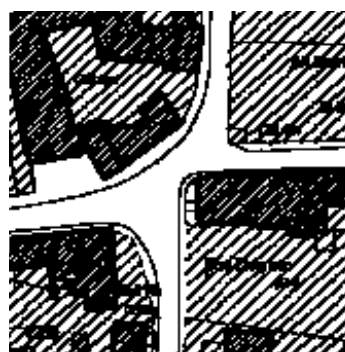

Offset junction, Harbury, Feldon area

6.2.13 Bends, curves and chicanes should not be placed arbitrarily but should be associated with or as a response to some other feature either existing or proposed such as ground levels, trees, hedges, buildings, open spaces etc. This applies in particular to speed reduction features such as bends, chicanes and pinch points.

6.2.14 Speed reduction features should be integrated into the overall design of the street as a whole. To that end, a mixture of measures should be used. Schemes employing only speed reduction bends, for example, are unlikely to be acceptable. Other features that should be considered include pinch points, chicanes, priority changes at junctions, staggered junctions and overwidened junctions.

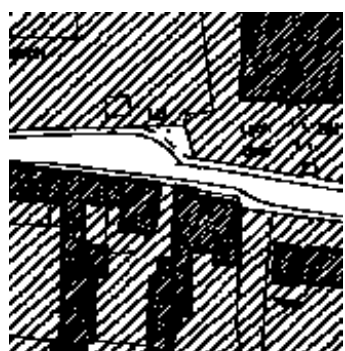

Pinch point, Harbury, Feldon area

6.2.15 Examination of existing settlements reveals there are many specific points in highways that by chance manage to function as speed reduction features (see illustrations right). Such examples should be used as a starting point for how best to design measures that are well integrated with surrounding development.

Design and use

6.2.16 Traditionally, streets have been used for a variety of purposes not only the movement of pedestrians, cars, buses, lorries, horses and cycles but also, in many cases, other activities such as markets, fairs, parades and street parties. While recognising that the principal use of highways has been, and remains today, movement, they should be conceived and designed as multi-functional spaces.

6.2.17 The detailed design of the carriageways, footways and verges should be simple and allow for a range of possible uses.

6.2.18 Kerb lines, for example, do not always have to be used to strictly delineate parking bays and turning heads. Space for on-street parking, bus stops and, where necessary, turning heads can be accommodated in widened street spaces. Kerb lines should relate to, and be integrated with, surrounding plots, buildings and other features such as trees and public open space. **Turning heads in particular should be integrated with other features so that they appear to be, and can be used as spaces for other, informal, purposes.**

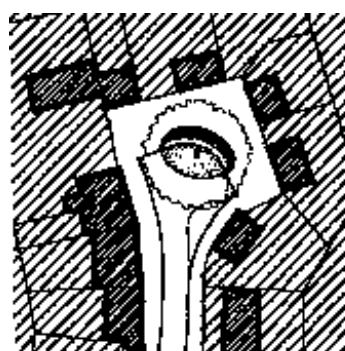

An example of a turning head integrated with the surrounding plot series

6.2.19 Similarly, the design of open spaces should be simple and allow for a variety of activities rather than a single use. For further indications for the design of open space see section 4.5

6.2.20 Within the highway, shrub planting should be kept to a minimum with the exception of boundary or linear features

Sample Analysis SHEET 6

Kineton

Highways

The carriageway of Banbury Street within the village

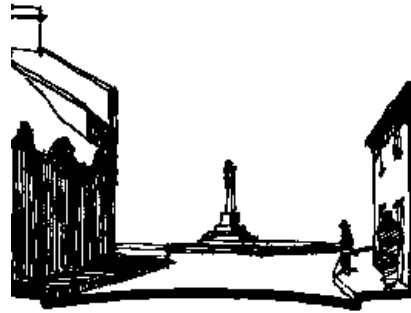

A section through Banbury Street looking west toward the monument

What is the position of the highway?

Looking at the specific example of the western end of Banbury Street, this segment of the highway is part of a primary route through the village and connects to the main junction with Warwick Road and Southam Street. The street space contains the War Memorial, a significant landmark in the village. In addition, the street at this point widens out to form a space that is very nearly if not quite fully a square and contains much of the commercial activity of the village. It is also worth noting that this space accommodates car parking and might allow for a market, fair or festival.

The western end of the Banbury Street carriageway



junction with Warwick Road it is approximately 16 metres wide, frontage-to-frontage, opening out to about 22 metres and at the junction with Manor Lane the highway opens out to its widest point of about 30 metres. Further east, it narrows down again to its narrowest of 10 metres.

What is the internal arrangement of parts?

Like many highways, this part of Banbury Street includes a carriageway flanked either side by footways. In the widened area between the junction with Manor Lane and Warwick Road there is a tapering oblong area of grass. This splits the carriageway into two, one slightly narrower than the other. The wider of the two follows the line of the main route. Because there is a slope across the street and the grass area is more or less flat, there is a retaining wall on the lower side. The War Memorial is located toward the wider end of the grassed area and thus in a more central position within the street space as a whole.

What is the shape and size of the highway?

This portion of Banbury Street curves in a fairly constant arc. It is very likely that the carriageway follows the line of a route that existed before the settlement was formed. It is equally likely that the line of the original route was a response to the slope and the junction with Manor Lane, amongst other things. The carriageway takes a fairly gradual route up from the river to the crossroads and widens at the junction with Manor Lane. Appropriate to its position as a main route, the highway is relatively wide. At the

Are there typical associations between position and internal arrangement?

On primary and secondary streets in Kineton there are generally two footways, one on each side of the street. On tertiary routes there are sometimes two and sometimes one or none, the number and width varying along the street. On modern culs-de-sac there are generally two standard footpaths, one each side though in some cases (in general, older dead end lanes) the number and width is variable.

Islands tend to be used in widened areas of the street to define separate carriageways

Carriageways, footways and islands

6.2.21 The arrangement of carriageways and footways within the highway is such a familiar figure it hardly seems necessary to specify the position of a footway, for example. But as becomes clear when looking at different streets, the arrangement is not always the

same in detail. Also, position seen at higher levels can give strong clues as to what is appropriate in detail for carriageways, footways or islands.

6.2.22 The dimensions of an element of the highway should vary in response to the site, to its location within the settlement as a whole and others features making up the street. For instance, wider footways are likely to be more appropriate in the centre as opposed to the edge of the settlement.

6.2.23 The materials used for highway surfaces and related elements should be appropriate to the settlement as a whole and the position of the highway within the settlement and the range of materials acceptable for the purposes of adoption.

Examples of highways from other settlements



High Street, Welford-on-Avon, Avon Valley area, a primary route with (left to right) verge, carriageway, verge and footway



Church Lane, Welford-on-Avon, Avon Valley area, a secondary route with (left to right) verge, carriageway and verge



Main Street, Cherington, Cotswold Fringe area, a primary route with (left to right) footway, carriageway and footway



Wood Lane, Cherington, Cotswold Fringe area, a cul-de-sac with (left to right) small verge, carriageway and footway



Henley Road, Great Alne, Arden area, a primary route with (left to right) footway, verge, carriageway and large verge with trees



Park Lane, Great Alne, Arden area, a secondary route with (left to right) verge with trees, carriageway and verge

*Sample Analysis, SHEET 7
Kineton*

**Carriageways,
footways and islands**

**What is the shape and size of the
carriageways, footways and islands?**

Within the bounds of the highway as a whole, the width of the carriageways, island and pavements along Banbury Street vary in a complex but complementary way. The close relationship between the parts makes it difficult to discuss the shape and size of any one part in isolation. The pavements vary in width relative to the building line but generally expand and contract with the overall width of the highway. Similarly, the width of the carriageway

varies, kerb-to-kerb, expanding and contracting with the overall width of the highway. The oblong island occupies the widest part of the highway, splitting the carriageway into one larger and one smaller carriageway. The shape of the island varies so the width of the two carriageways either side remains constant as the overall width of the highway changes. The footpaths range from less than a metre to more than four metres wide and the carriageway from about 7 metres to 25 at the widest point. The island is 7 metres at its widest point.

It is noticeable that the variation of the widths is subtle and gradual, following generally, but not exactly, the curve of the building line. The kerb lines define both the carriageway and footpaths in smooth, continuous curves. But while they are smooth and continuous, they are not precise, circular curves. The result is a balance between continuity and variability, formality and informality.

Plot series

6.3.1 There is an important connection between the street pattern and plots series. The connection is well illustrated by the example of a curve in the street. In order to maintain a continuous building line of public fronts along a curved street, the plot series must be adjusted from a standard rectangular shape. One solution is to splay the plots with each plot tapering to the back. Examination of settlements in the District shows that, in general, plot series are adjusted to suit different situations such as curves, junctions or physical features. Generally, the only place a regular series of rectangular plots is found is along a straight section of street between junctions **The general principle that follows from this is one of the most important in this guide.**

6.3.2 The shape, size and arrangement of plots within a series should VARY to suit the situation and position within the street pattern.

6.3.3 A standard plot size and shape should not be used throughout a development. This applies in particular to curving streets, junctions and irregular site boundaries. It is very unlikely, for example, that the staggering of standard rectangular plots to accommodate a curve will be acceptable.

6.3.4 Specific proposals for plot series should be based on series found in equivalent positions within the settlement where development is to occur. Attention should be paid to the characteristic associations between the position of a series and its internal arrangement.

A series of splayed plots accommodating a curve

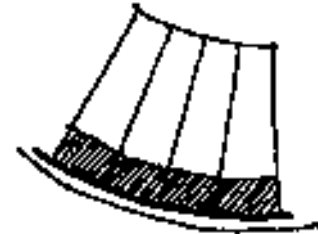

A series of staggered plots, an unacceptable way of accommodating a curve



Sample Analysis SHEET 8 Kinton

Plot series



Plot series within the street and village



The plot series making up Banbury Street, Kinton

What is the position of the plot series as part of the street as a whole?

Looking at the series on the north side of the western end of Banbury Street, Kinton, it is on the inside curve of the street and backs onto a number of plots that are part of Mill Street including the single large plot of Court Close. At a

higher level of scale, the series is on the end of the street toward the centre of the village, near the main junction with Warwick Road and Southam Street. The series also faces the junction with Manor Lane. The frontage of the series forms the boundary between the public realm of the highway and the private realms within the plots.

What is the shape and size of the plot series?

Each plot has a straight front at a slight angle relative to the plot either side and approximates the curve of the highway. The back boundary is shared with the back and side boundaries of other plots and follows a broken line of straight segments. The depth of the series varies from about 10 metres to 50.



Plot series, north western end of Banbury Street, Kinton

What is the internal arrangement of parts?

The main components of the plot series are, of course, individual plots. There is a variety of plots in terms of shape and size and the number, location and arrangement of buildings. For the most part the plots are deeper than they are wide. It is also noticeable that they are wider at the front and taper down toward the back of the series. This allows each plot to have a front following the line of the street and to extend more or less straight back.

6.3.5 In general, within most parts of settlements in the District, plot series are oriented to reinforce the line of the street. Buildings on the plots tend to be arranged with the main ridge line parallel to the line of the street. Other features such as front boundaries tend to reinforce that line. Further, there tends to be a significant number of plots with the same orientation within a series in order to adequately define the street space. In particular, the orientation tends to remain the same for not less than 5 plots.

6.3.6 Plot series should be oriented to reinforce the line of the street and of sufficient size in length along the street to adequately define the street space.

6.3.7 Variations in orientation must be exceptions within an identifiable tendency. Several significant changes in orientation over short distances along a street, are unlikely to be acceptable.

6.3.8 In certain circumstances, the area on the outside of a sharp bend in an street presents a special situation. The corner creates a relatively 'dead' or inaccessible area. A common response to this situation is a sub-series with a private drive running off the corner of plots parallel to one leg of the street. **This solution to the problem should be avoided.** A preferable solution would be to use the corner space for parking with a shared access.

6.3.9 Within a more or less regular plot series along a straight stretch of street, there are often variations in plot size within a limited range and occasional larger variations.

6.3.10 In new development, the plot widths within a series should not be uniform across the whole series but should vary within a limited range. Exceptional, large plots should also be considered and in the appropriate circumstances are encouraged.

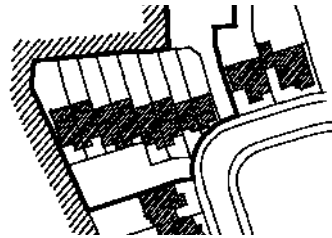

Unacceptable solution to the 'dead corner' problem

6.3.11 An alternative to a large single plot is a 'sub-series' of smaller plots that work together visually as a larger single plot, for example, a multiple occupancy detached building associated with a large garden or open space.



A courtyard series, Upton, Haselor, Arden area



A shallow series, Mill Street, Kineton

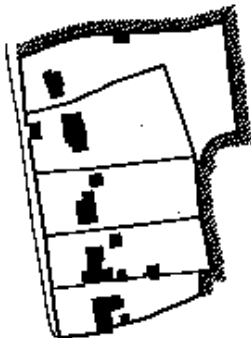

A series of wide, deep plots, High Street, Welford-on-Avon, Avon Valley area



A corner combination, Chapel Street/High Street, Welford-on-Avon, Avon Valley area



A series of deep, narrow plots, Chapel Street, Welford-on-Avon, Avon Valley area



A series with a courtyard combination, Main Street, Cherington, Cotswold Fringe area

Plots

- 7.1 Variation and position
 - Corner plots
- 7.2 Building position
 - Frontage set-back
 - Orientation to street
- 7.3 Density
- 7.4 Gardens and boundary features
- 7.5 Parking

Variation and position

- 7.1.1 Virtually every settlement includes a range of different plots in terms of size, shape and the arrangement of the building or buildings. There is often variation from centre to periphery across the settlement as a whole as well as variation along a street and within an individual plot series.
- 7.1.2 There are four basic types of plot frequently found in most settlements in the District - **detached, semi detached, terraced and courtyard**. These terms are more commonly associated with house types. They apply equally - and in some ways more accurately - to plots. **It is the position of the main building within the plot, relative to the street and adjacent plots and buildings**

Plots with houses set at or near the frontage forming a clear building line



that determines if a house is, for example, detached or semi-detached. Aside from the party wall, the houses themselves may or may not be different.

- 7.1.3 The position of a plot within a series and the position of the series within a street can present very different circumstances to which specific designs must respond.
- 7.1.4 New development should include a range of plot types. Larger developments using a single plot type are unlikely to be acceptable.
- 7.1.5 Plots should vary in terms of size, shape and internal arrangement depending on the position of the plot within a series, within the street and within the settlement as a whole.
- 7.1.6 Variation of plots, within a series and along a street, should not be arbitrary but a response to particular circumstance. The starting point for selecting which types should be used in a particular position should be the range found in similar positions within the existing settlement.

- 7.1.7 New designs to meet new needs should be adaptations of local types. Again, attention should be paid to typical associations between the position of a plot and its internal arrangement.

Corner plots

- 7.1.8 The most common case where a variation of type is appropriate is at corners. Even within a plot series adapted to a corner position, the plot in the vertex of the corner presents a special situation.
- 7.1.9 The plot occupying the corner should be a variation adapted to the position in terms of one or more of the following aspects: shape, size, the arrangement of the building or buildings, the building type and orientation of access and openings.



Plots with the house set back from the highway but a well defined frontage line

Building position

Frontage set-back

- 7.2.1 A particularly important aspect of plots is the position of the main building relative to the street. In many settlements in the District, the arrangement of buildings on the plot results in a strong building line.
- 7.2.2 In cases where development is proposed within an existing street with a well defined building line, proposed buildings should normally maintain the established line. Exceptions may be considered in special circumstances.
- 7.2.3 In cases where the main building is set back from the highway and the frontage is defined by a wall, hedge or fence, new development should maintain the frontage line with an appropriate treatment.
- 7.2.4 In development involving the creation of new streets, the amount of set back and resulting building line should be appropriate to the character of the street and its position within the hierarchy of routes and the settlement as a whole.

7.2.5 The amount of set-back must be related to the street as a whole and, as noted above with respect to streets, the front-to-front dimension should be appropriate to the position of the street within the settlement.

While commonly accepted standards (70 feet/ 21 metres) may be used as a point of reference they should not be taken as rigid rules. At the same time, this should not be deemed as tacit acceptance of smaller dimensions applied uniformly or mindlessly.

Orientation to street

7.2.6 In general the main building should be oriented parallel or perpendicular to a highway or plot boundary. This applies both to attached and detached types.

7.2.7 Exceptions are only likely to be acceptable in the case of a detached house with very large gardens on all sides.

7.2.8 Detached houses set at arbitrary angles on small plots should be avoided.

Side-to-side distances

7.2.9 In the case of detached and semi-detached types, the set-back from the side boundary or boundaries should be suited to the position and size of the plot and the size and type of building.

7.2.10 Large houses with minimum side set-back should be avoided.

7.2.11 Narrow frontage, deep plan house types should not be used as detached houses.

7.2.12 Narrow front deep plan houses are best rotated 90 degrees to be wide frontage, shallow depth. This arrangement is more flexible. It can be more easily adapted to different positions within a street and plot series. It is also more easily altered internally and extended without a negative impact on daylighting.

7.2.13 In the appropriate circumstances, terraced types are encouraged for a number of reasons. They provide a positive definition of the street space leading to a clearer, less visually cluttered building line. Detached types, on the contrary, tend to result in a crowded appearance when used at current average densities. This is in part due to the fact that detached types raise the expectation of larger gardens and more planting which tends not to be fulfilled.

7.2.14 With terraced types, higher densities can be achieved reducing the amount of land taken up by development leaving more land for planting and other uses. Because there are shared walls, terraced types also help reduce heat loss in individual houses and so reduce total energy consumption. **It is essential that terraced types have sufficient sound proofing. The construction of party walls should result in a sound barrier equivalent to detached types set at a minimum side-to-side distance.**

Sample Analysis SHEET 9 Kineton

Plots

A plot within Banbury Street, Kineton



What is the position of the plot as part of the series as a whole?

Looking at the plot series on the north side of the western end of Banbury Street, the plot is in the middle of the series. To either side is a plot with a terraced house set directly at the back of the pavement. These establish a distinct building line which is continued in both directions by front boundary walls and other buildings to form a continuous 'street wall'. The plot in question also fronts the widest part of the street and sits

directly opposite the junction with Manor Lane. In that position it is subject to particular scrutiny from people entering Banbury Street from Manor Lane.

What is the shape and size of the plot?

The plot is approximately 8 metres wide and an average of 28 metres deep from the front to the back boundary. The plot is an 'L' shape with the 'foot' of the L wrapping around a smaller plot to the east.

What is the internal arrangement of parts?

The main building sits on the frontage directly on the boundary with the public highway and the main roof ridge is parallel to the street line. The gable walls are on the side boundaries. The rear of the plot is occupied by garden with a small outbuilding toward the rear.

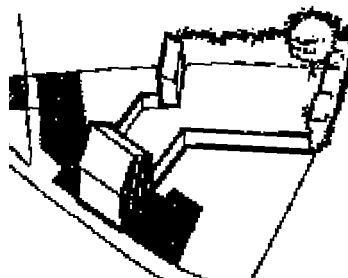

The components of a plot: house, outbuildings, garden and boundary features

Examples of plots from other settlements

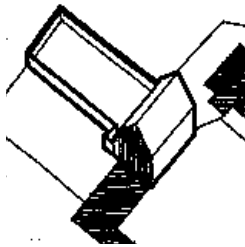

A plot in a courtyard complex, Upton, Haselor, Arden area

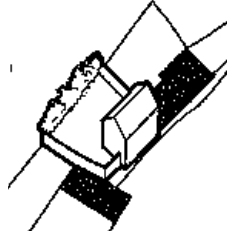

A shallow plot with the house attached on one side and the front on the highway boundary, Mill Street, Kineton

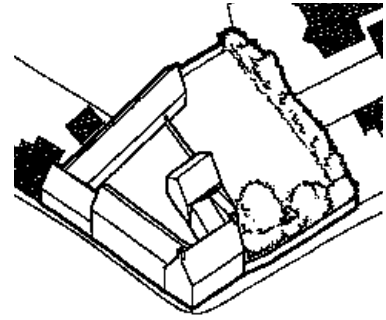

A square corner plot with a courtyard arrangement of buildings, Banbury Street/Warwick Road, Kineton



A narrow, deep plot, mid terrace, set back from the highway, Chapel Street, Welford-on-Avon, Avon Valley area



A corner plot, with a composite main building with one side attached and set back from the highway, Chapel Street/Main Street, Welford-on-Avon, Avon Valley area

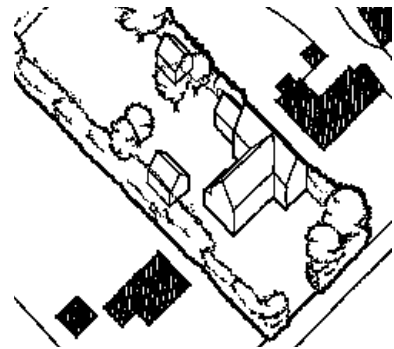

A wide, deep plot with the main house set well back and one side on a side boundary, High Street, Welford-on-Avon, Avon Valley area

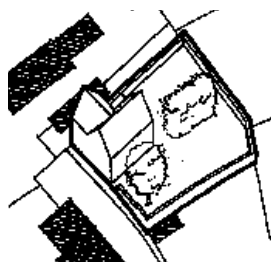

An end of cul-de-sac plot with the house on the frontage and a side boundary, Wood Lane, Cherington, Cotswold Fringe area

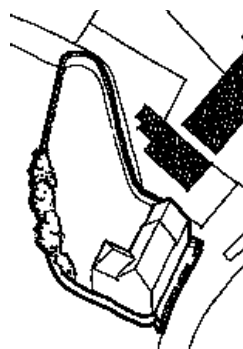

An end of series plot with the house occupying the full width and set back a short distance from the highway, Main Street, Cherington, Cotswold Fringe area

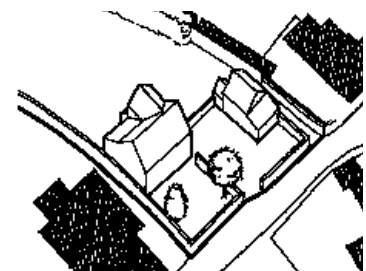

A wide, deep plot with main and outbuilding set back from the highway, Stourton, Cotswold Fringe area

Density

7.3.1 The density of residential development is fundamentally related to the size of plots and the amount of building on each plot. Density is most commonly measured in houses per acre or hectare. This is not the most accurate measure of building density because of the significant differences in size and occupancy levels between different house types. For example, a development of 10 five bedroom houses on an acre is denser than 10 two bedroom house on the same area.

7.3.2 It is essential that proposals for development should include a table or schedule stating the net developable area, the total number of houses, the floor area and storey number per house type, and the total floor area of building.

7.3.3 Central government advice on the question of housing density is tending to support the idea of raising densities at or immediately surrounding places with good public transport facilities. The intention is to improve the viability of local services and reduce the need to travel for services. **In the context of Stratford-on-Avon District, the issue of higher densities needs to be set against the issue of local character, particularly in the smaller rural villages.**

7.3.4 New development should balance considerations of character and density. Application of a uniform density across the District or even within a specific settlement is unlikely to be appropriate.

7.3.5 Working with existing settlement patterns, the most appropriate basis for variation in density is a general gradient along two main lines:

- the urban/rural distinction,
- centre/periphery.

7.3.6 Within Stratford-on-Avon District, the urban/rural distinction is more one of larger rural town to small rural village. Higher densities will thus be more appropriate in larger towns as opposed to small villages or hamlets.

7.3.7 Densities within a particular settlement might vary from centre to periphery. It is important to note that 'centre' in this context is an area of concentration of buildings and/or services.

7.3.8 In many cases, the centre is located near or radiates out from a cross roads or along the central axis of the main route through the settlement. There are cases, however, in which the area of concentration is not at the physical or geographical centre of the settlement. Equally, some settlements have two or more such centres.

7.3.9 Within a settlement, higher densities will be more appropriate toward the centre. In certain instances multiple centres will be acceptable. Any sub-centre, however, must have ready access from a primary or secondary route and/or public transport.

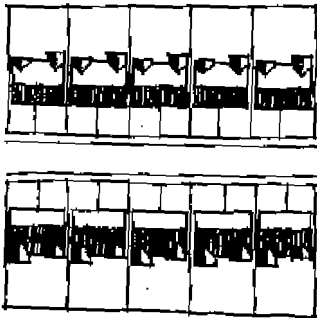

A one acre scheme with ten five bedroom, detached houses

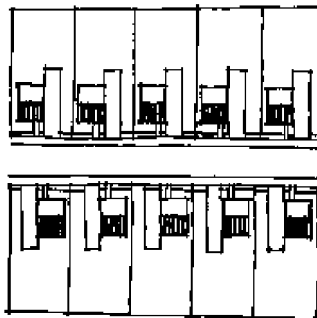

A one acre scheme with ten two bedroom detached houses

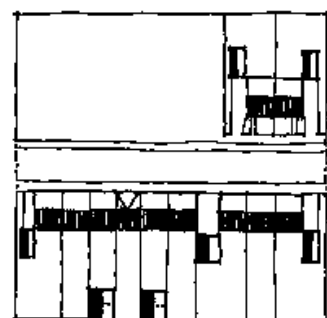

A one acre scheme with ten two bedroom terraced houses

Gardens and boundary features

7.4.1 The position, shape and size of gardens is a function of the position of the building within the plot. Depending on the plot type, there might be front, side and back gardens. For guidance on the matter of planting, please refer to section 4.5.

Garden size

7.4.2 As with front-to-front dimension, commonly accepted standards may be used as a point of reference (11 metre gardens to achieve a 70 feet/ 21 metre back-to-back dimension) but should not be taken as rigid rules. At the same time, this should not be deemed as tacit acceptance of smaller dimensions applied uniformly or mindlessly.

Boundary features

7.4.2 In cases where the main building on a plot is set back from the boundary with the highway, the feature, if any, that defines the boundary makes a significant contribution to the character of the settlement. Typical treatments vary from one character area to the other and from one sub-area to the next. In many cases there is a variety of treatments within a settlement. Further, on a given plot, treatments can vary between front, side and rear boundaries.

7.4.3 Plot boundary treatment should be appropriate to the position of the boundary within the plot, the street, settlement and character area. The choice of proposed feature (in terms of position, shape, size, details of construction and materials) should be based on the range found in similar positions within the settlement where development is to occur.

7.4.4 There are five basic forms of boundary treatment commonly found in the district:

- stone walls,
- brick walls,
- timber fences,
- metal railings,
- hedges.

See page 70 for illustrations of examples.

7.4.5 The Character Map of the District gives indications of dominant wall materials as do Conservation Area documents. The materials used in stone and brick walls should ideally be of local provenance or matching appropriate local materials in shape, size, colour and texture. It should be noted that characteristic materials for boundary walls are in some cases not the same as those for the walls of houses and other buildings. For hedges, please refer to the section 4.5 and Appendix D.

7.4.6 Boundaries facing open countryside, public rights of way or public open spaces should NOT be close board fence. Picket, pale, post and rail or hit and miss fencing or orchard railing is more likely to be appropriate in such cases, generally in association with hedging. Walling may be appropriate in some cases.

Close board or other solid fencing should generally be restricted to side and back boundaries shared with other built up plots.

Parking

7.5.1 The question of the amount of parking to be provided within new development is subject to guidance at various levels, in particular, PPG 3 and Stratford-on-Avon District Planning Practice Notes. This guide focuses on the design of parking when policy dictates inclusion.

7.5.2 The position of parking within development clearly depends on the plot types used and the building types within the plot. The position and character of the street as a whole is a further consideration and constraint.

7.5.3 Different solutions to the problem of how and where parking should be accommodated will be appropriate for different positions within a settlement.

7.5.4 Parked cars should not visually dominate development. Solutions that place the majority of parked cars between the front of the house and the carriageway should be avoided.

7.5.5 If parking is accommodated within the plot, it should be placed within, beside or behind the plan outline of the main building.

7.5.6 Garaging that is integral with the main house should not project forward of the main facade of the house. Preferably it should be flush with or set back from the main front. Integral garages might be fully enclosed or form a 'through' garage providing access to the rear garden.

7.5.7 Another preferred solution is shared parking to the rear of houses with a common entrance.

7.5.8 With terraced plots, the entrance might be through a gap between houses or a carriageway with building over. Shared parking to the rear of houses is best limited to a relatively small number of cars per shared area. It is also essential that there is sufficient overlooking of the parking area from the houses.

7.5.9 In some cases, on-street parking or grouped parking within the highway or on a private drive may be acceptable. In terms of detail, such areas should not be designed as mono-functional spaces - solely for parking. They should appear as integral parts of the street with simple outlines, for example, taking the form of a 'public square'.

7.5.10 Particular solutions should be appropriate to the position within the settlement and street and should start with examples found in similar circumstances in the settlement in which the development takes place.

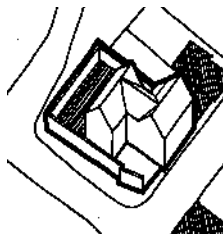

Parking at the side of the house, Henley-in-Arden, Arden area

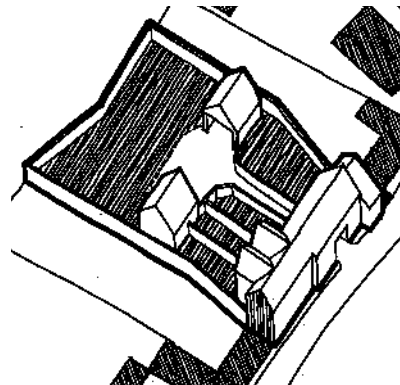

Shared parking at the back of the plot, Ardens Grafton, Avon Valley area

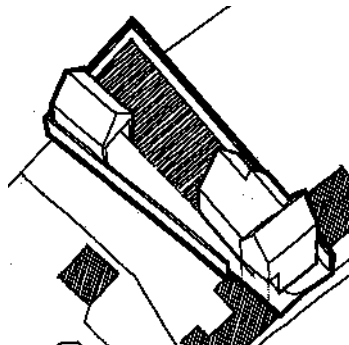

Parking at the back of the plot, Ardens Grafton, Avon Valley area

- 8.1 Variation and position
- 8.2 Form, components and innovation
- 8.3 Extensions
- 8.4 Non-residential buildings

Variation and position

- 8.1.1** The building is in many cases the most obvious component of a plot. The overall form and detail of buildings thus have a significant impact on the character of a street. The positions occupied by buildings within a plot and the position of the plot within a series and street present a variety of circumstances. In existing settlements there tends to be a variety of buildings that adjust to or take advantage of the particular circumstances of a given position.
- 8.1.2** The main body of buildings within the settlements in Stratford District fall within the general category of ordinary vernacular buildings. For the most part they are relatively simple in overall form. To say simple is not to say uniform. Within the limits of simple geometric shapes, there tends to be a range of types found in the District with a variety of specific dimensions, arrangements and detail treatment. The range of variation is often related to location, from main character area down to position in a street or series. Variation also depends on the status of the house and type of construction.
- 8.1.3** New development should include a range of building types within a family of simple overall forms.
- 8.1.4** Type and size should vary depending on the position of the building within a plot, within the plot series and street and within the settlement as a whole. Uniform treatment of buildings in terms of type, dimensions and detail is unlikely to be acceptable.
- 8.1.5** Variation of type and size within a plot series and along a street should not be arbitrary or excessive. The starting point for selecting which types should be used in a particular position should be the range of types found in similar positions within the existing settlement. In looking at the settlement, ask whether there are typical associations between a position and particular kinds of building.
- 8.1.6** Type and dimensions should be based on forms appropriate to the material and type of construction of the building.

Sample Analysis SHEET 11 Kineton

Buildings

What is the position of the building as part of the plot as a whole?

The example from the plot on Banbury Street is a fairly common one. The plot is a terraced type in the middle of a series. To either side is a terraced house set directly at the back of the pavement and gable walls on the side boundaries.

What is the shape and size of the building?

Like the houses either side, the house in question occupies the full width of the plot with shared gable walls on the side boundaries. The house is rectangular in plan and approximately 8 metres wide by 7 metres deep. It is approximately 4.3 metres high to the eaves with a simple gable (or double pitched) roof with an angle of between 35 and 40 degrees.

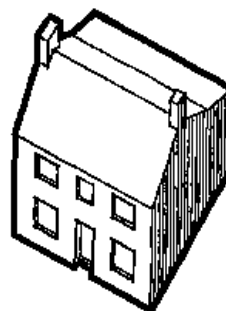

A 'two unit' terraced house with a symmetrical arrangement of openings

What is the internal arrangement of parts?

The house is two storeys and has a 'two-unit' plan (two rooms wide) with a central stair. As can be seen from the position of the chimneys, there are fireplaces on the gable walls. The front facade is symmetrical with a central door flanked by windows and the ground and first floor windows are vertically aligned along their central axis. The ground floor window openings are taller than the first floor windows and there is a blank window on the first floor centred over the door.

Examples of buildings from other settlements



One-unit, one and a half storey attached house with end stack, Great Alne, Arden area



One-unit, two storey attached house with end stack, Stratford-upon-Avon, Avon Valley area

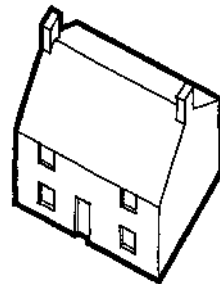

Two-unit, two storey detached house with central hall and end stacks, Stretton-on-Fosse, Cotswold Fringe area

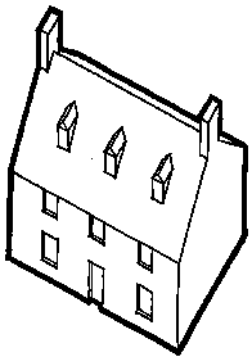

Two-unit, two and a half storey attached house with central hall and end stacks, Kineton, Feldon area

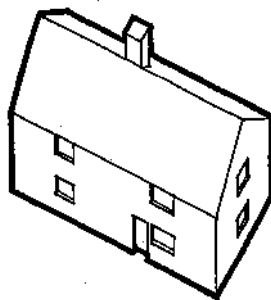

Two-unit, two storey detached house with central stack and off-set door, Great Alne, Arden area

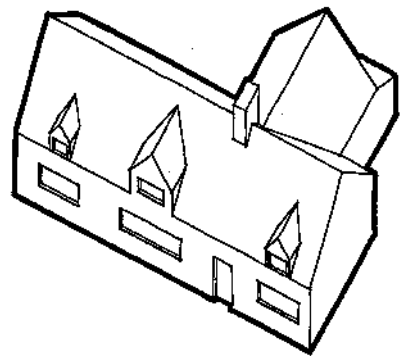

Three-unit, T plan, one and a half storey detached house with central stack and multi-light windows, Long Marston, Avon Valley area

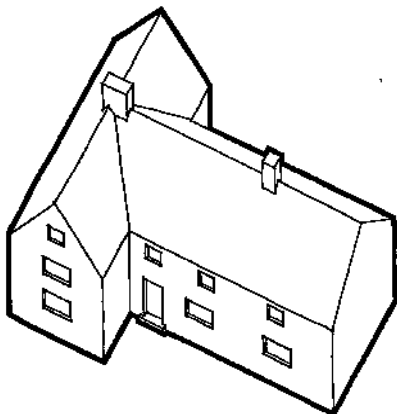

Two-storey, cross wing T plan detached house with central stacks and multi-light windows, Priors Marston, Ironstone Uplands area

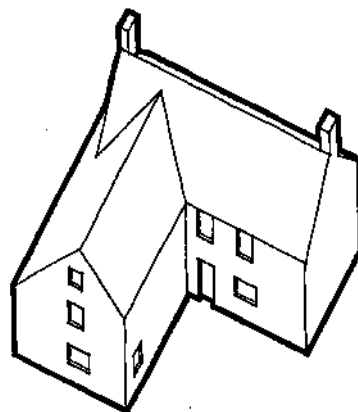

L plan two storey detached house with end stacks, Fenny Compton, Cotswold Fringe area

Form, components and innovation

8.2.1 In the case of residential development, the predominant overall form of house types within the District is rectangular in plan, oriented parallel to the front plot boundary, two storeys high with a simple gable roof. The plan depth of most houses tends to be between 5 and 7 metres with the roof ridge parallel to the long axis. 'L' and 'T' plan forms with the projection to the rear are also relatively common.

8.2.2 The predominant forms within a settlement should be the starting point or reference for new designs.

8.2.3 As far as possible designs should be simple and robust to facilitate adaptive reuse.

8.2.4 The following points are particularly important:

- plan depth of new houses should be kept to a minimum;
- the roof ridge should run along the long axis of the building;
- projections and extensions such as outshuts, lean-tos or projecting gables should be to the side or rear;
- hipped roofs are unlikely to be acceptable except on detached houses and limited in number;
- half-hip, gabled and mansard roofs are unlikely to be acceptable;
- houses on corner plots should be 'double fronted' with two 'public' sides facing the public highway.

8.2.5 Innovation with specific and explicit aims is encouraged.

8.2.6 A principal aim of design should be a balance between innovation and local character. Designs based on the transformation of local forms are encouraged. Use the logic of local forms as a stimulus for creativity.

8.2.7 The Council encourages approaches that make use of, amongst other things, daylighting, natural ventilation, passive heating and cooling, retention and reuse of rainwater and greywater and improved insulation to reduce total energy and resource use. Both traditional methods and recent developments in these areas should be considered.

8.2.8 As far as possible, windows should be placed to optimise solar gain within the house and reduce the need for heating.

8.2.9 Particularly at the level of the building, there are many small improvements that can make a significant difference in energy use. For more information on what those improvements might be see the information available through the Energy Advice Centre at the District Council offices.

Extensions

8.3.1 Given the nature of most buildings in the District, appropriate extensions will most likely be simple elements.

8.3.2 The starting point for extensions should be the forms and components of the original building and the logic of the type.

For example, flat fronted types should remain flat fronted with extensions to the side or rear. Equally, detached or semi-detached houses should retain some characteristic of separation.

8.3.3 On the basis that the predominant form of building in the District is flat fronted, the most common forms of extension are the following:

- outshut or lean-to rear extension (single storey, extending the existing roof)
- single storey gabled rear extension
- two storey gabled rear extension
- lean-to side extension
- single storey gabled side extension
- two storey gabled side extension

8.3.4 The result of the extension should normally be the transformation of one type characteristic of the location to another.

An example is the transformation of a simple two storey detached house by a series of steps to a larger 'L' type. The original house, two rooms wide with a central stair, is enlarged by a sequence of small extensions to a building three rooms wide with a rear wing.

Typical sequence of transformation illustrating different kinds of extension

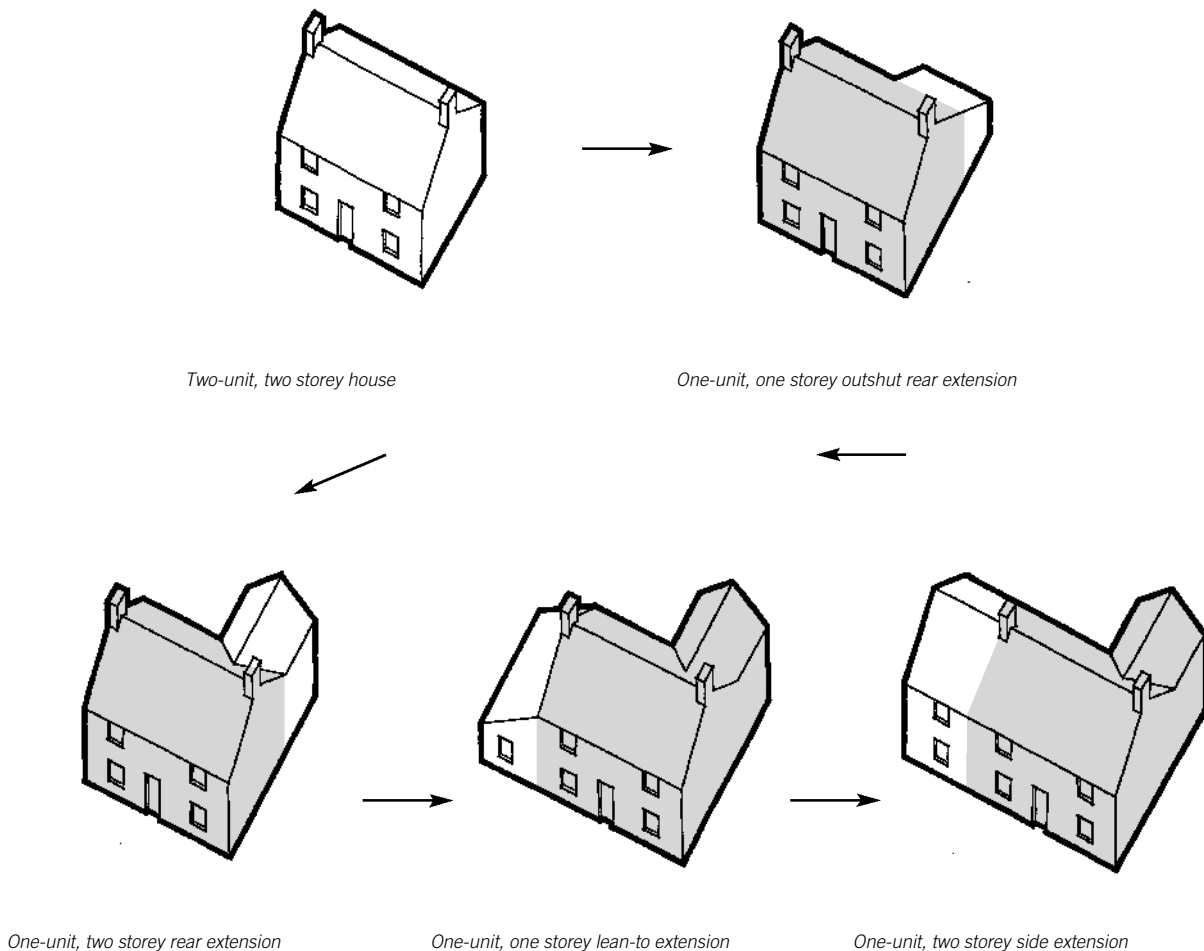

Non-residential buildings

8.4.1 Non-residential development involves a great variety of different activities and needs. There is thus no clearly identifiable, predominant type for 'non-residential' building. In many parts of the district, however, non-residential uses are currently accommodated in buildings that were originally intended for residential or a split use between retail/commercial on the ground floor and residential on upper floors. On the one hand, new uses or needs often demand new, innovative forms. On the other hand, simple forms characteristic of traditional buildings often continue to successfully accommodate a range of current uses.

8.4.2 Reuse of existing buildings for new uses is encouraged.

8.4.3 As far as possible designs should be simple and robust to facilitate adaptive reuse.

8.4.4 Innovation with specific and explicit aims is encouraged.

8.4.5 A principal aim of design should be a balance between innovation and local character. Designs based on the transformation of local forms are encouraged. Use the logic of local forms as a stimulus for creativity.

8.4.6 The Council encourages approaches that make use of, amongst other things, daylighting, natural ventilation, passive heating and cooling, retention and reuse of rainwater and greywater and improved insulation to reduce total energy and resource use. Both traditional methods and recent developments in these areas should be considered.

8.4.7 In some cases, predominant traditional forms can be taken as a 'module' which might be doubled or, in limited cases, repeated as a basis for a larger building.



The former polo school, now the Learning Resource Centre, Warwickshire College, Morten Morrell. The contemporary detailing of the stairs, floor and lift play off the original roof truss. The innovation works with and complements the traditional elements. Photo courtesy of Robothams Architecture



Office development in Preston Bagot, Arden area, incorporating both conversion and new build. The overall form of the new building, above, is an adaptation of the basic rectangular plan, gabled building form. Relative to the basic form the ground floor area has been extended using a low pitched roof, picking up a buttress form. The gentle curve in plan is unexpected and enlivens the building while the basic form is still recognisable.



The adaptation of the basic building form is also accomplished by the innovative use of materials. The large areas of glass, galvanised steel and timber extend the traditional palette of brick, clay tile and stone yet, again, the overall effect is a recognisable form that is not at odds with the character of the locality. Photos courtesy of Systems by Design.

Looking at the design and choice of Details and materials

9

9.1 General principles

9.2 Examples and specific principles

General principles

9.1.1 In spite of the diversity of details across the District, there are a number of principles that apply more generally. The following section sets out those principles and illustrates a sample of some of the more commonly found details.

9.1.2 Most ordinary houses in Stratford-on-Avon District are relatively simple in detail. Despite the simplicity, however, most settlements are characterised by a variety of details - within definite limits. The variety and specific details depends on the location - which village and where within the village the details are found. The range of details of a particular house also depends on the status, material and type of construction of the house. There is a logic to the choice of details leading to **characteristic associations of details**.

9.1.3 There are four broad principles that should apply to details and materials in Stratford-on-Avon District.

- Details should be simple.
- Within appropriate limits, there should be a variety of details from house to house.
- The limits to the range of details should be based on what is appropriate to the settlement and position within the settlement.
- The limits should also be based on what is appropriate to the material and type of construction of the building.

9.1.4 In this context simplicity should not be interpreted to mean, as it sometimes is, stripped down, shoddy or cheap. Nor should it be associated with a particular period or style. **Simplicity is not a matter of quality or style but rather the degree of elaboration.** In general, traditional vernacular buildings, which make up most of the buildings in the District, are relatively unadorned by elaborate features. This is not to say the buildings were not the product of considerable care and attention. On the contrary, it is the care and attention that has been paid to the basic structural features, seen as decorative details, of vernacular buildings that so often gives them their appeal.

9.1.5 Historically, the degree of elaboration of details has tended to be associated with the status of the house. Larger, higher status houses tend to have more elaborate detailing. As a result, the relative frequency of elaborate details is low. More elaborate detailing is less frequent and conversely, less elaborate detailing is more frequent.

9.1.6 The negative associations commonly attached to simple detailing can often be accounted for by the excessive and sometimes mindless repetition of the details. In contrast, most settlements in the District are characterised by **variety - within definite limits**. There is variety within a range. There tends to be a 'family resemblance' or common theme between houses with each showing a variation on the theme. In order to maintain this aspect of settlements and avoid the negative impact of excessive repetition, the same set of details should not be used across an entire development, however small.

9.1.7 Families of details tend to be associated with particular locations and particular building materials and types of construction.

9.1.8 The family of details that should provide the starting point for proposals should be identified by an examination of existing details found in the particular part of the settlement in which the new development is to take place.

9.1.9 The most appropriate starting point will be the families of details used in buildings of the same or similar material and type of construction as proposed.

Sample Analysis SHEET 12 Kineton

Details

What is the position of the detail as part of the building as a whole?

The range of component details is fairly broad. For the purposes of this sample analysis, looking more closely at one element should provide an illustration of the basic points to follow. Windows provide a good example.

In the case of the house on Banbury Street, comparing the windows reveals that the design varies with the position. The ground floor windows are taller than the first floor windows. It is also noticeable that the facade includes a blind window. There are thus three 'types' of window on the front of the building.

What is the shape and size of the detail and what is its specific nature?

Each of the different types of window is a different shape and size. The ground floor windows are approximately 1.2 metres wide and 1.5 metres high (a proportion of 4:5). The glazed windows on the first floor are approximately 1.2 metres square (1:1) while the blind window is 1.2 metres height and about 0.9 metres wide (3:4).

All the window openings have flat arches in stone, four brick courses high (280mm) with a slightly projecting keystone. The jambs of the openings are plain brick and the cills are thin stone (about half a brick high - 30mm) with a projection of about the same dimension. The blind window has the same head and jamb detail but no cill.

The frames of the windows are modern replacements and somewhat unusual. All are two light painted timber casements opening from the central mullion. The sub-frame is set back from the face of the wall by approximately 20mm. The casements are flush closing as opposed to 'storm-proof' with a projecting external flange. The lights of the ground floor frames are two panes wide by four high, and the first floor two by three. All the panes are the same size, about 240mm wide and vertically oriented (about 2:3). The glazing bars are moulded and approximately 20mm wide as seen from outside. The panes are modern single glazed sheet glass as opposed to double glazed or older crown glass.

The same approach can be taken for the other elements that make up the full range of details.

Examples and specific principles

9.2.1 Within the District there are three predominant types of traditional construction:

- timber frame,
- brick,
- stone

9.2.2 There are four predominant types of traditional roof material found within the District: **plain tile, Welsh slate, straw thatch and stone tile.** The typical associations of roof materials with the three main construction types are:

- with timber frame: thatch and clay tile roofs;
- with brick: clay tile and slate roofs;
- with stone: thatch, stone tile, clay tile and slate roofs.



A close studded timber framed house with rendered infill panels in Long Itchington, Feldon area



A brick house with rubbed brick flat arch window heads in Henley-in-Arden, Arden area



A house of Cotswold Limestone laid in coursed rubble with ashlar quoins, Barton-on-the-Heath, Cotswold Fringe Area

9.2.3 The character map of the District identifies the areas in which each construction type is commonly found. Distinct sets of details have developed for each material and, in the case of stone, for the main types of stone found in the District: **Blue Lias, White Lias, Cotswold and Hornton**. Some of the variations in details are illustrated in the examples below.

To the right, Cotswold Stone (Oolitic Limestone); to the left, Blue Lias



Hornton Stone (Marlstone Rock Bed)

White Lias (Langport Member Limestone)



Brick

Timber frame construction

9.2.4 Traditional structural timber framing is encouraged in the appropriate locations within appropriate settlements. Mock traditional timber framing will not normally be acceptable.

9.2.5 Modern structural timber framing is also encouraged using a cladding appropriate to the location of the proposed development

Brick and stone construction

Roofs

9.2.6 Stone tile is found almost exclusively within the Cotswold Fringe area. The details appropriate in a particular case will depend on the material. As plain tile is the most common material, the following examples show mainly plain tile roofs.

Plain clay tiles



Welsh Slate



Verge, eaves and ridge

9.2.7 The most common verge detail is trim with a tile or slate undercloak. Barge boards and boxed eaves should be avoided as should decorative ridge tiles. Stone-coped gable parapets are normally only used in stone construction.

A stone-coped gable parapet of Hornton stone with a corbelled verge/eaves junction known as a kneeler. Avon Dassett, Cotswold Fringe area



A trim verge of brick with slate undercloak, a projecting stretcher course and a simple angled ridge tile in Lower Quinton, Avon Valley area

Dentilated brick eaves made up of a projecting stretcher course, alternating projecting headers and a further projecting stretcher course. Priors Marston, Ironstone Uplands area



A trim verge of brick with stepped projecting header corbelling and a half-round ridge tile in Alcester, Arden area



Plain eaves with exposed rafter feet on a brick building, Ullenhall, Arden area

Variation of dentilated brick eaves with alternating projecting headers on edge, also showing a rise-and-fall gutter fixing, Great Alne, Arden area



Plain eaves, trim verge and mortared ridge on a Cotswold Limestone house, Great Wolford, Cotswold Fringe Area

Chimneys

Simple brick chimney with single course corbelled weathering, Ardens Grafton, Avon Valley area



9.2.8 Chimneys are most commonly located at the main ridge. Very frequently they are found on the gable ends in which case they are most often flush, with an internal breast. Most are rectangular in plan, oriented at right angles to the ridge. Virtually all chimneys have a cap, corbelled weathering and chimney pots.



Simple coursed rubble stone chimney of Cotswold Limestone with single course weathering, Stretton-on-Fosse, Cotswold Fringe Area



Brick chimney with elaborated corbelled weathering, Henley-in-Arden, Arden area



Cotswold Limestone ashlar chimney with moulded weathering, Cherington, Cotswold Fringe Area

Dormers



Well positioned and sized dormers. They are smaller than, and vertically aligned with, the windows below. The lights of the dormer casements are also similar to those of the windows in proportion and glazing pattern.

A simple dormer with lead cheek walls and a render gable. Note that the sub-frame of the window is part of the main structure of the dormer. Also note the dentilated eaves detail and single course segmental arch window head.



9.2.9 Caution should be exercised in the use of dormers. In many villages they are not common features. In cases where they are appropriate, the number should be limited to avoid clutter. The position of the dormer within the roof should be either just above the eaves (between the top plate and lower purlin), mid-way up the roof (between purlins or above a single purlin) or, exceptionally, with the cill of the dormer below the eaves level. In the latter case, care must be taken with the position of rainwater pipes. In all cases the dormer ridge should be well below the main roof ridge.

9.2.10 The dormer should be smaller in height and width than the window openings below and, as far as possible, should be vertically aligned with them. Cheek walls should be as narrow as possible and faced in either lead or render as should the gable. The eaves of the dormer roof should be below or at the same level as the window head, not above. Simple gabled dormers are the most common. Hipped dormers are acceptable in some settlements. Flat roofed dormers with cornice moulding may be acceptable on buildings in a Classical idiom.

Rooflights

9.2.11 Like dormers, rooflights should be smaller in height and width than the window openings below and, as far as possible should be vertically aligned with them. Ideally they should be set flush with the roof surface.

Brick construction:

Walls

9.2.12 The characteristic brick colour in the District can best be described as orangey-pink or pinky-orange. There is, of course, variation within that description in a range from an almost pink buff to a fairly strong terra cotta orange. Claret and other darker reds, browns, ochre or beige buffs, greys and blues are unlikely to be acceptable.



A house with walls built in Flemish bond with buff headers, Wellesbourne, Avon Valley area. The windows have flat brick arch heads and stone cills. Note that the cills are slightly wider than the window opening.

9.2.13 Use of contrasting detail brick is not common in the District and should be done with restraint. Detailing is most often done with the same brick as the main wall, as is the case in the examples shown here. If contrasting bricks are used, the difference in colour and tone should be minimal. An example found relatively frequently in the District is Flemish bond walls with buff headers. Another example is the use of finer quality bricks for gauged brick arches. Specials of blue brick are sometimes used for window cills. Plinths on brick walls are almost never found in the District and should not be used.

Window and door openings

9.2.14 In most cases openings should be vertically aligned, with openings over openings. Vertical alignment is particularly important on small facades. On smaller houses and cottages, first floor windows are often set just below the eaves line with only the top plate or several courses of bricks over the opening. Most window openings are vertically oriented but there is considerable variation including square and some horizontally oriented. The most common horizontally oriented opening is a three-light casement with vertical lights divided by mullions. The proportions of the lights are often about 3:2, height-to-width.

9.2.15 As a general rule, window and door openings must have visible means of support for the material above. The most common traditional solutions found in the District are segmental arches, flat arches or stone lintels. In some cases, flat arches or lintels are rendered or stuccoed to look like stone.

9.2.16 A range of cills is found in the District and preferred forms include stone, plain clay tile and brick. In the case of brick, special bricks such as single cant on edge or plinth stretchers are preferable. Wood may also be used but only of sufficient size and combining a stub cill and sub-cill. Projecting integral cills are unlikely to be acceptable.



Gauged brick flat arches on a house in Henley-in-Arden, Arden area. The openings are vertically aligned and the second floor windows are smaller than the first floor windows.



A window with a segmental arch head in Alcester, Arden area. Note that the arch is made up of one course of headers on edge and one course of headers laid flat, a detail very characteristic of brick areas within the District.



Cottages with windows set just below the top plate in Welford-on-Avon, Avon Valley area. The casement windows shown are flush closing as opposed to 'storm proof'



Render used to create the effect of stone lintels in Wellesbourne, Avon Valley area. The windows have stone cills and sliding sash frames.

Stone construction:

Walls

9.2.17 There are four main building stones found in Stratford-on-Avon District: Cotswold Limestone, Hornton Marlstone, Blue Lias and White Lias. The terms used to describe the source beds of these building stones are Oolitic Limestone ('Cotswold'), Marlstone Rock Bed ('Hornton' or 'Ironstone') and Langport Member Limestone ('White Lias'). The bed for Blue Lias is called simply Blue Lias. All these stones are members of the same family (Jurassic and Triassic Limestones) but due to their specific characteristics, they tend to be cut and laid in somewhat different ways.

9.2.18 In general, the most common method of building with all four stones is coursed, squared rubble, usually with quoins. In virtually all cases there is variation in the course depth, the quoins are larger than the rubble making up the wall and the coursing runs through to the joints between quoins.

9.2.19 The principal difference between methods of laying is generally due to the size of individual stones. The size depends on nature of the stone. Blue Lias is one of the most variable, both in colour and size of rubble. This leads in some cases to a distinctive pattern of wall, with alternating courses of larger, blue and smaller yellow-grey stones, often without quoins.

9.2.20 Cotswold and Hornton Stones are also quite variable in colour. Some Cotswold stones have a high iron content and can, in colour, look similar to 'Hornton Ironstone'. There is, however, a distinct difference in the structure of the stone and therefore in the way it weathers. Cotswold Limestone is Oolitic and considerably harder. Marlstone is a Liassic stone and quite soft. Care must be taken, therefore, in the selection of stone. Most villages are predominantly one stone or the other but attention should be paid to differences within villages. While there

A building in Ardens Grafton, Avon Valley area, built of Blue Lias coursed rubble stone with alternating courses of large blue and small yellow-grey stones. This pattern is typical of the Avon Valley area and the southern part of the Lias Uplands of the Feldon area.



Coursed, squared rubble of Cotswold Limestone with quoins to the right. Note that the line of the joint between the quoins runs through to the joints between courses of rubble. This is known as coursing through.



A good example of a double pile house built in White Lias with Cotswold Limestone dressings in Halford, Stour Valley area. The windows have very fine sliding sash frames set back from the face of the building and stub cills over the stone sub-cill

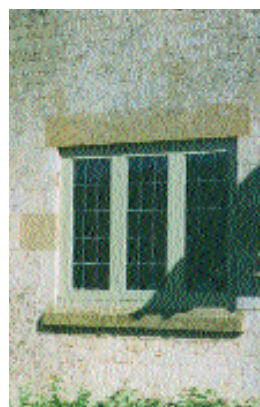

A three-light, flush closing casement window in a square opening. The lintel and cill are of finer, dressed stone. Great Wolford, Cotswold Fringe Area



A Hornton stone farmhouse with a four-light, stone mullioned window. The window has flush head, jambs and cill with a label or hood mould above the head

may be one predominant wall material, in some cases there are distinct areas within villages with different predominant materials.

9.2.21 Established patterns of mixing types of stone in one building may be followed. In some areas, for example, Blue Lias is used for the body of the wall and Hornton Stone for dressings.

Window and door openings

9.2.22 Because stone and brick are similar building materials - small squared units bound together with mortar - similar details are used with both. Thus, as with brick, in most cases of stone construction, openings should be vertically aligned with void over void. Vertical alignment is particularly important on small facades. On smaller houses and cottages, first floor windows are often set just below the eaves line with only the top plate or several courses of stone over the opening. Most window openings are vertically oriented but there is considerable variation including square and some horizontally oriented. In horizontally oriented openings, individual lights are vertically oriented and divided by mullions. The proportions of the lights are often about 3:2, height-to-width. Probably the most common horizontally oriented opening is a three-light casement.

9.2.23 As a general rule, window and door openings must have visible means of support for the material above. The most common traditional solutions found in the District are segmental arches, flat arches or lintels in squared rubble or dressed stone as well as oak lintels.

9.2.24 A range of cills are found in the District and preferred forms include stone, stone tile and plain clay tile. Wood may also be used but only of sufficient size and combining a stub cill and sub-cill. Projecting integral cills are unlikely to be acceptable.

Window frames and door leafs - all forms of construction

9.2.25 The window frame should normally be set back from the face of the building to give a shadow line. The presence and design of glazing bars or lead comes should be suited to the opening size, the position of the window in the building and the overall form of the house. If casements are proposed, they should normally be traditional or modern flush closing as opposed to 'storm proof' designs which have projecting external flanges.

9.2.26 Energy note: In many cases the most significant heat loss through existing windows, both casement and sash, is due to drafts as opposed to the thermal value of the glass. This is to say that greater improvements can often be achieved for less investment by ensuring the windows are properly draft proofed rather than replacing windows with double glazing. Also, thicker single glazing, (6mm) can provide nearly the same thermal value as double glazing.

9.2.27 The type of door proposed should suit the building type and the position of the door within the building. Simple vertical plank doors are generally suited to smaller 'cottage' type buildings and moulded panel doors to larger houses. Glazing on doors should follow the same pattern as the windows.

Canopies - all forms of construction

9.2.28 Canopies and porches are not characteristic of many of the building types in the District though in many cases they have been added. Care should therefore be taken in applying them to new designs. One of the most common types of canopy is a simple double pitch or lean-to roof on brackets. Less commonly the canopy is supported on posts. Another common type is a flat, moulded projection on brackets. Cheek walls and fully enclosed porches are rarely found and should be avoided as should hipped roofs.

Vents and service boxes - all forms of construction

9.2.29 All vents and service boxes to be included in a proposed building should be indicated on the submitted drawings. All such items should be as inconspicuous as possible.

Other materials

9.2.30 Modern timber or steel construction is encouraged, with a cladding appropriate to the settlement.

Render

9.2.31 Caution should be exercised in the use of render. The acceptability of render is dependent on the character of the specific village and location within it. Partial render will not normally be accepted.

Mixing materials

9.2.32 Extreme caution should be exercised in combining different external materials in the same building. In general there should be one principal external material.



A double pitched canopy on posts, Ilmington, Cotswold Fringe area



A double pitched canopy on brackets, Great Wolford, Cotswold Fringe area



Lean-to canopies on brackets, Welford-on-Avon, Avon Valley area. The roof material in this case is inappropriate



A flat canopy on brackets, Wootton Wawen, Arden area

Examples of frontage and boundary features from various settlements



A boundary with planting and pale fence, Tanworth-in-Arden, Arden area



A pale fence, Priors Marston, Ironstone Uplands area



A dry stone wall of Hornton Stone, Radway, Cotswold Fringe area

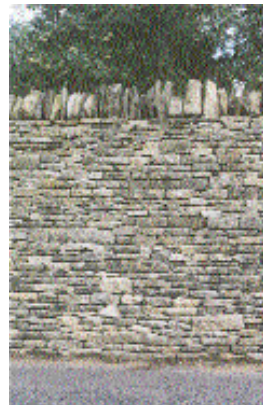

A drystone wall of Cotswold Stone, Long Compton, Cotswold Fringe area



Iron orchard rail, Combrook, Feldon area

See section 7.4, page 53, for further details

Conversion of traditional agricultural buildings

Appendix A

- A.1 The principle of conversion
- A.2 The setting of the barn
- A.3 Existing structure
- A.4 Repairs
- A.5 New structure
- A.6 Windows and doors
- A.7 Roofs
- A.8 External walls
- A.9 Extensions

The principle of conversion

A.1.1 The conversion of redundant agricultural buildings is subject to specific policies in the Stratford-on-Avon District Local Plan. The acceptability of conversion is dependent on a number of factors including the proposed new use, the location of the building and its construction. Please refer to the Local Plan for the information required in applications for conversion. The following principles refer primarily to matters of design in the conversion of buildings.

The setting of the barn

- A.2.1** Barns acceptable for conversion are generally found in farmyard settings, often still related to the original farmhouse and other secondary agricultural buildings.
- A.2.2** In all cases conversion should involve a minimum of change in order to maintain the agricultural character of the setting.
- A.2.3** In cases of residential or holiday rental conversion it is particularly important to avoid creating a domestic, residential feel. Elements such as patios and paths, screen fences, flower borders and swimming pools will not normally be permitted.
- A.2.4** Where the original farmhouse remains, the converted barn should remain secondary and subservient to the farmhouse. This is often a matter of simplicity of character rather than relative size.
- A.2.5** Within an existing farmyard group, walls and old outbuildings should be retained and repaired in order to screen and enclose domestic items (including, for example, liquid gas or oil containers). The construction of new walls to the same effect may in some cases be acceptable.
- A.2.6** If possible, garaging should be provided within existing adjoining structures. New structures modelled on traditional forms and appropriate to the setting in position, form and detail may be acceptable.
- A.2.7** In large multi-occupation schemes the garaging should be grouped to form one building.
- A.2.8** Some hedging or tree planting is usually desirable. All planting should be suitable indigenous species as set out in the species lists found in Appendix D.

A.2.9 Driveways, courtyards and paths should be gravelled. Concrete kerb edging and concrete flags should not be used though brick or cobbles may be appropriate in some cases.

A.2.10 Farm courtyards as defined by the original buildings should not be subdivided. When garden boundaries are appropriate they might take the form of brick or stone walls or hedges of a suitable species planted in association with unobtrusive fencing.

Existing structure

- A.3.1** As much as possible of the existing structure should be retained in its original position, including (but not limited to):
 - main wall framing members: storey posts, wall or top plates, sill or sole plates, tie beams and main bracing; main masonry walls; primary trusses or other structural roof elements; wall and wind bracing; stud-work and rafters; brick and stone plinths.
- A.3.2** New openings should be placed to keep the loss of original framing or masonry to a minimum. This applies equally to principal structural framing, bearing walls, stud-work, rafters and plinths.

Repairs

- A.4.1** Traditional methods involving the least loss of original fabric should be the first choice for repair. With timber, for example, if the damage is limited, members should be scarfed or patched. If damage is more extensive, replacement would be preferable. Large areas of patching, facing or resin repairs of timber is unlikely to be acceptable.
- A.4.2** Materials used in repairs and replacement must match existing timber, brick or stone.
- A.4.3** In cases where the building is rapidly deteriorating, a programme of immediate repair works may be a condition of planning permission.

New structure

- A.5.1** Inserted first floors will often need to be supported by a new independent structure. If it is proposed to construct an inner loadbearing skin to the external walls then a proper provision for good ventilation of the cavity should be made - especially where the external walls are timber framed.
- A.5.2** Other partitions must be made of the same material and construction as the existing walls OR be structurally independent so as to avoid movement problems.
- A.5.3** In threshing barns, a substantial part of the internal volume, preferably that within the midstrey, should be maintained as a full height space (floor to ridge) to retain the open character of the original building.
- A.5.4** Permanent internal fittings such as staircases should suit the utilitarian and agricultural character of the building. Detailing of a domestic character, particularly in historic styles, is unlikely to be acceptable.
- A.5.5** New structure within open fronts to buildings such as calf or cattle sheds should be lightweight in nature such as glazing or timber boarding rather than masonry. The rhythm of bays should remain as a strong visual element.

*Simple brick barn,
Aston Cantlow,
Arden area*



*Sensitive
conversion in Long
Compton with
simple, restrained
flush closing
casement windows
and rooflights set
flush with the roof.*



Windows and doors

- A.6.1** The arrangement of windows and doors should be suited to the structure of the building. The number and size of windows should be kept to a minimum, the purpose being to provide adequate levels of daylight and not primarily to provide views. Open plan arrangements of internal partitions are likely to provide the best solution for lighting large areas with a minimum of openings.
- A.6.2** The preferred location for windows and doors is within existing openings, former openings that have been filled in, panels within timber framing or in areas where the existing fabric is damaged, decayed or has been modified to an extent beyond repair.
- A.6.3** The main wagon doors are usually the most obvious location for large windows and external doors. Any original door frame should be retained if possible. The primary structural frame and secondary framing for new glazing and doors should be made of sawn hardwood (elm or oak) and positioned behind any existing frame in order not to compromise the original fabric and to emphasise the opening with a reveal and shadow line. As a general rule, the midstrey entrances should express their former status as wagon doorways either by full glazing or sealing the great doors.



*Great Wolford.
Appropriate
treatment of the
midstrey, retaining
the full height of
the opening.*

- A.6.4.** Other new windows should be robust, timber framed, of simple design and should match the framing details of any existing small door or window openings.
- A.6.5** Manufacturer's standard windows are unlikely to be acceptable particularly those with 'storm proof' casements, 'Georgian' glazing bars or thin projecting cills.
- A.6.6** New doors should be of simple boarded or plank construction. Moulded panel doors and other historic styles are unlikely to be acceptable.
- A.6.7** External joinery may be painted or stained or, if oak, left to weather naturally. Bright paint colours, however, and ginger or mahogany stains should be avoided.

Roofs

- A.7.1** The intention must be to retain the roof profile, form and materials as far as possible. Velux or similar small rooflights may normally be used sparingly but must be of the 'conservation' type and must be set as nearly flush with the roof surface as possible. Over use of small rooflights should be avoided. In some situations relatively large areas of patent glazing may be used. Dormer windows should not be used as they unacceptably disrupt the profile of the roof.
- A.7.2** Many barns have had more than one roof covering in the course of their life. Where the roof is of straw thatch or stone slate, a change of material is unlikely to be permitted. Slate or clay tiles whether original or replacement should also be retained. More recent roofs of sheet metal or asbestos should be replaced with thatch, natural slate or clay tiles, whichever is most appropriate.
- A.7.3** External brick chimney stacks are uncharacteristic features on many agricultural buildings, particularly threshing barns, and should only be used in appropriate cases. Where flues are required they should be metal, minimal in size and painted or stove enamelled with a dark matt finish. They should be located in an unobtrusive position. Soil and vent pipes should be taken to discharge at a high level, preferably through a gable rather than through the main roof.

Timber framed barn with brick infill, Haselor, Arden area



External walls

- A.8.1** Exterior cladding materials should not be changed. Replacement weatherboarding should be of a similar size and profile and must be dark stained. Where barns are partly boarded and partly brick, minor revisions to the area of each material may be acceptable where it suits the structure and character of the building. In particular, original weatherboarding should be retained or replaced - like for like.
- A.8.2** Minor external features such as hatches, ventilation, dove and owl holes and pentice boards should be retained and repaired or replaced like-for-like if necessary.
- A.8.3** Rainwater goods and downpipes should be unobtrusive and neatly detailed. Preferably they should be metal, not plastic and always be painted in a colour to make them as unobtrusive as possible. If timber troughing remains it must be retained or replaced like-for-like.
- A.8.4** Brick and stone walling should be carefully repaired where necessary with matching reclaimed material and should be repointed with soft lime mortar of appropriate colour.

Extensions

- A.9.1** Extensions will not normally be acceptable. Small outshuts or lean-tos in the traditional manner may, however, be acceptable where necessary to link buildings. Domestic porches, other small extensions and conservatories will not be acceptable.
- A.9.2** Extensions subsequent to the initial conversion are unlikely to be permitted. Depending on the potential environmental impact of further changes to converted buildings, some permitted development rights may be withdrawn as a condition of planning permission.



Converted barn in Moreton Bagot, Arden area. Note that the openings are contained within the timber frame structure



Shopfronts and signage

Appendix B

- B.1 General considerations
- B.2 Shopfronts
- B.3 Signs and advertisements

General considerations

B.1.1 The character and appearance of buildings and streets can be affected to a surprising degree by shopfront design, signs and advertisements. Ill-considered and overly intrusive designs can have a very detrimental effect. At the same time, the right design in the right place can be a very positive contribution to the overall scene.

B.1.2 As many examples attest, when there are too many signs and shopfronts screaming for the attention of a limited number of passers-by the situation can lead to an escalation in the desire to grab attention. The next new sign has to be bigger and brighter than the last in order to stand out. The escalation tends to create a kind of visual noise that drowns out all the signs. The result is an over-intensive and often disruptive visual environment. Such an environment is generally at odds with the overall character of most settlements in the District. The result can also be a degradation in the quality and attractiveness of the street as a place for trading and commercial activity.

B.1.3 The overriding principle for the design of shopfronts and the design and placement of advertisements should be restraint.

B.1.4 Signs and shopfronts should work within the overall form and structure of a building and be subservient to it.

A good example in Stratford-upon-Avon. The window framing works with the structure of the building.



Shopfronts

B.2.1 There is considerable variation in the design of shopfronts across the District. The starting point for any design should, therefore, be the shop building itself and other shops in the immediate surroundings. Information submitted with an application should show the entire building both as existing and proposed. Supporting information showing examples of other shops in the area of the proposal can also be helpful.



A good example of a shopfront in Shipston-on-Stour. The display windows fit within the main structure and retain the vertical emphasis of the other windows.

B.2.2 A shopfront should suit the type and style of the building seen as a whole.

B.2.3 If, for example, the building is symmetrical, the design of the shopfront should maintain the overall symmetry. If the building is in a Classical or Georgian style, for example, some of the characteristic features that define the style should be carried forward into the new design such as proportions of openings, patterns of glazing or moulding profiles.

B.2.4 If a blind is proposed it should be retractable, ideally the type that is integral with the shopfront and retracts into the fascia.

B.2.5 Fixed blinds of the curved plastic type are seldom compatible with the buildings in most commercial areas and will normally be resisted. It should be noted that any non-retractable blind on the front face of a building requires Planning Permission. Also, blinds that include advertisements may require Express Consent as discussed below.

B.2.6 In all cases the shopfront should remain subservient to the building and appear as a component part of it.

Signs and advertisements

- B.3.1** The display of advertisements is controlled by the Town and Country Planning (Control of Advertisements) Regulations 1992. The following sets out the policy which the District Council has adopted regarding the control of advertisements.
- B.3.2** In many instances Express Consent is required for advertisements. Also, in parts of Stratford-upon-Avon there are areas of special control in which the restrictions on advertising are more rigorous. To determine which regulations apply in a particular instance, please contact a District Council Planning Officer.
- B.3.3** The following guidance applies generally to proposed signs and advertisements within the District and especially those that require Express Consent or Listed Building Consent.
- B.3.4** The overriding principle for the design and placement of advertisements should be restraint.
- B.3.5** The aim should be to create an environment in which the buildings and activities themselves are the principal attraction and visual interest, not the signs.
- B.3.6** In general, signs and advertisements should be kept within the commercial, 'shopfront' area. This tends to be limited to the ground floor, street frontage of the building.
- B.3.7** Signs should remain secondary to any individual building and help to maintain the character and rhythm of the building and the street frontage.
- B.3.8** Signs should not clutter or dominate the facade of a building nor, by extension, the entire street frontage.
- B.3.9** The colour, material and illumination of signs should be subdued and not harsh or aggressive.

Position and size

- B.3.10** Signs should be positioned to work within the structure of the shopfront or building
- B.3.11** Signs and advertisements should be positioned below the level of the first floor window cill.
- B.3.12** No signs should be displayed on an elevation that does not contain a shop window or main customer entrance.
- B.3.13** Where no proper frontage or fascia exists, signs are best made up of individual letters fixed to the external wall or window glass.
- B.3.14** No fascia or sign should run continuously across two or more adjacent buildings.
- B.3.15** The lettering and symbols of signs, particularly on fascias, should not exceed 40cm. in height.



Two good examples of signage in Stratford and Shipston. The lettering is restrained and kept within the structure of the building.

Hanging signs

- B.3.16** Depending on the height of the building, brackets for hanging signs should be fixed so that the sign hangs at a level between the ground and first floor windows. In some cases a hanging sign may be positioned between the cill and head of the first floor window. It is very unlikely that a hanging sign positioned above the head of a first floor window will be acceptable.
- B.3.17** Hanging signs should be restricted to one per shop or business.
- B.3.18** The size of hanging signs should be proportionate to the building.
- B.3.19** It should not dominate the facade or obscure architectural details or adjacent buildings. Lettering and symbols should be proportionate to the size of the sign.
- B.3.20** Painted or low relief boards should be used as opposed to 'box' signs.
- B.3.21** In the interest of contributing to the liveliness and quality of the street scene, pictorial, iconic or 'object' signs are encouraged as are well designed decorative brackets.

Well placed and inventive panel and object hanging signs in Shipston.



Content

- B.3.22** As a general rule, the content of all signs should be limited to the name, nature and services of the shop or business. Advertising for particular brands or products should be avoided.

Illumination

- B.3.23** External illumination of buildings and signs will normally be resisted. Careful flood-lighting of key buildings of particular architectural quality may, however, be permitted and in some cases encouraged.
- B.3.24** Limited lighting of hanging signs and fascias may be allowed in the case of businesses open in the evening such as restaurants, pubs, theatres and clubs but not in addition to floodlighting. In such cases, the principal purpose of the external lighting should be to make signs legible at night. The lighting should not be a feature in itself and the fittings should be as small and unobtrusive as possible.
- B.3.25** No signs may be internally illuminated with the exception of signs indicating medical supplies.

Materials

- B.3.26** The materials and construction of signs and advertisements should be robust and of high quality. The signs should appear solid and permanent as opposed to flimsy and temporary.
- B.3.27** Harsh and shiny or reflective surfaces such as many acrylics and plastics and chrome should be avoided as should bright and garish colours.

List of principal villages in character areas

Appendix **C**

Abbots Salford	Avon and Stour Valleys,	<i>Avon and Arrow terraces</i>
Admington	Avon and Stour Valleys,	<i>Stour vale</i>
Alcester	Arden,	<i>Alne and Arrow valley floors</i>
Alderminster	Avon and Stour Valleys,	<i>Stour vale</i>
Alveston	Avon and Stour Valleys,	<i>Upper Avon</i>
Ardens Grafton	Avon and Stour Valleys,	<i>Avon ridgelands</i>
Arlescote	Cotswold Fringe,	<i>Scarp foot and slope</i>
Armscote	Avon and Stour Valleys,	<i>Stour vale</i>
Arrow	Arden,	<i>Alne and Arrow valley floors</i>
Ashorne	Feldon,	<i>Lias uplands</i>
Aspley Heath	Arden,	<i>Birmingham plateau fringe</i>
Aston Cantlow	Arden,	<i>Alne and Arrow valley floors</i>
Atherstone-on-Stour	Avon and Stour Valleys,	<i>Stour vale</i>
Avon Dassett	Cotswold Fringe,	<i>Scarp foot and slope</i>
Barcheston	Avon and Stour Valleys,	<i>Upper Stour</i>
Barton	Avon and Stour Valleys,	<i>Avon vale</i>
Barton-on-the-Heath	Cotswold Fringe,	<i>Fringe downlands</i>
Bascote	Feldon,	<i>Lias uplands</i>
Bascote Heath	Feldon,	<i>Lias uplands</i>
Bearley	Arden,	<i>Ancient Arden</i>
Bidford	Avon and Stour Valleys,	<i>Avon vale</i>
Binton	Avon and Stour Valleys,	<i>Avon ridgelands</i>
Bishops Itchington	Feldon,	<i>Lias uplands</i>
Blackwell	Avon and Stour Valleys,	<i>Stour vale</i>
Blunt's Green	Arden,	<i>Ancient Arden</i>
Brailes, Lower	Cotswold Fringe,	<i>Scarp foot and slope</i>
Brailes, Upper	Cotswold Fringe,	<i>Fringe downlands</i>
Broom	Avon and Stour Valleys,	<i>Avon and Arrow terraces</i>
Buckley Green	Arden,	<i>Alne and Arrow valley floors</i>
Burmington	Cotswold Fringe,	<i>Fringe downlands</i>
Burton Dassett	Cotswold Fringe,	<i>Scarp foot and slope</i>
Butler's Marston	Feldon,	<i>Lias uplands</i>
Chadshunt	Feldon,	<i>Clay vale</i>
Charlecote	Avon and Stour Valleys,	<i>Upper Avon</i>
Cherington	Cotswold Fringe,	<i>Broad valleys</i>
Chesterton	Feldon,	<i>Lias uplands</i>

Claverdon	Arden,	<i>Ancient Arden</i>
Clifford Chambers	Avon and Stour Valleys,	<i>Stour vale</i>
Combrook	Feldon,	<i>Lias uplands</i>
Coughton	Arden,	<i>Alne and Arrow valley floors</i>
Crimscote	Avon and Stour Valleys,	<i>Stour vale</i>
Darlingscote	Avon and Stour Valleys,	<i>Stour vale</i>
Dean's Green	Arden,	<i>Ancient Arden</i>
Dorsington	Avon and Stour Valleys,	<i>Avon vale</i>
Dunnington	Arden,	<i>Arrow ridgeway slope</i>
Earlswood	Arden,	<i>Birmingham plateau fringe</i>
Edgehill	Cotswold Fringe,	<i>Ironstone plateau and valleylands</i>
Edstone	Arden,	<i>Alne and Arrow valley floors</i>
Ettington	Feldon,	<i>Lias uplands</i>
Exhall	Arden,	<i>Avon and Arrow terraces</i>
Farnborough	Cotswold Fringe,	<i>Scarp foot and slope</i>
Fenny Compton	Cotswold Fringe,	<i>Scarp foot and slope</i>
Forshaw Heath	Arden,	<i>Birmingham plateau fringe</i>
Fulready	Feldon,	<i>Clay vale</i>
Gaydon	Feldon,	<i>Lias uplands</i>
Gilbert's Green	Arden,	<i>Ancient Arden</i>
Great Alne	Arden,	<i>Alne and Arrow valley floors</i>
Great Wolford	Cotswold Fringe,	<i>Fringe downlands</i>
Halford	Avon and Stour Valleys,	<i>Stour Feldon edge</i>
Hampton Lucy	Avon and Stour Valleys,	<i>Upper Avon</i>
Harbury	Feldon,	<i>Lias uplands</i>
Haselor	Arden,	<i>Alne and Arrow valley floors</i>
Henley-in-Arden	Arden,	<i>Alne and Arrow valley floors</i>
Honington	Avon and Stour Valleys,	<i>Upper Stour</i>
Idlicote	Feldon,	<i>Clay vale</i>
Ilmington	Cotswold Fringe,	<i>Fringe downlands</i>
Kineton	Feldon,	<i>Lias uplands</i>
King's Coughton	Arden,	<i>Alne and Arrow valley floors</i>
Knightcote	Feldon,	<i>Clay vale</i>
Ladbroke	Feldon,	<i>Lias uplands</i>
Langley	Arden,	<i>Ancient Arden</i>
Lighthorne	Feldon,	<i>Lias uplands</i>
Lighthorne Heath	Feldon,	<i>Lias uplands</i>
Little Alne	Arden,	<i>Alne and Arrow valley floors</i>
Little Compton	Cotswold Fringe,	<i>Fringe downlands</i>
Little Kineton	Feldon,	<i>Clay vale</i>

Little Wolford	Cotswold Fringe,	<i>Fringe downlands</i>
Long Compton	Cotswold Fringe,	<i>Broad valleys</i>
Long Itchington	Feldon,	<i>part Mudstone vale, part Lias uplands</i>
Long Marston	Avon and Stour Valleys,	<i>Avon vale</i>
Loxley	Feldon,	<i>Lias uplands</i>
Luddington	Avon and Stour Valleys,	<i>Avon vale</i>
Mappleborough Green	Arden,	<i>Ancient Arden</i>
Marlcliff	Avon and Stour Valleys,	<i>Avon vale</i>
Moreton Morrell	Feldon,	<i>Lias uplands</i>
Moreton Paddox	Feldon,	<i>Lias uplands</i>
Morton Bagot	Arden,	<i>Ancient Arden</i>
Napton-on-the-Hill	Ironstone Uplands	
Newbold-on-Stour	Avon and Stour Valleys,	<i>Stour vale</i>
Newbold Pacey	Feldon,	<i>Lias uplands</i>
Newnham	Arden,	<i>Ancient Arden</i>
Northend	Cotswold Fringe,	<i>Scarp foot and slope</i>
Nuthurst	Arden,	<i>Birmingham plateau fringe</i>
Oldberrow	Arden,	<i>Ancient Arden</i>
Oldberrow Hill	Arden,	<i>Ancient Arden</i>
Oxhill	Feldon,	<i>Clay vale</i>
Pillerton Hersey	Feldon,	<i>Lias uplands</i>
Pillerton Priors	Feldon,	<i>Lias uplands</i>
Preston Bagot	Arden,	<i>Ancient Arden</i>
Preston Green	Arden,	<i>Ancient Arden</i>
Preston-on-Stour	Avon and Stour Valleys,	<i>Stour vale</i>
Priors Hardwick	Ironstone Uplands	
Priors Marston	Ironstone Uplands	
Quinton, Lower	Avon and Stour Valleys,	<i>Avon vale</i>
Quinton, Upper	Cotswold Fringe,	<i>Fringe downlands</i>
Radway	Cotswold Fringe,	<i>Scarp foot and slope</i>
Ratley	Cotswold Fringe,	<i>Ironstone plateau and valleylands</i>
Sambourne	Arden,	<i>Arrow ridgeway slope</i>
Salford Priors	Avon and Stour Valleys,	<i>Avon and Arrow terraces</i>
Shelfield	Arden,	<i>Ancient Arden</i>
Shipston-on-Stour	Avon and Stour Valleys,	<i>Upper Stour</i>
Shottery	Avon and Stour Valleys,	<i>Upper Avon</i>
Shotteswell	Cotswold Fringe,	<i>Ironstone plateau and valleylands</i>
Shuckburgh, Lower	Feldon,	<i>Clay vale</i>
Shuckburgh, Upper	Ironstone Uplands	
Snitterfield	Arden,	<i>Ancient Arden</i>

Southam	Feldon,	<i>Lias uplands</i>
Sperrall	Arden,	<i>Alne and Arrow valley floors</i>
Stourton	Cotswold Fringe,	<i>Broad valleys</i>
Stratford-upon-Avon	Avon and Stour Valleys,	<i>Upper Avon</i>
Stretton-on-Fosse	Cotswold Fringe,	<i>Fringe downlands</i>
Stockton	Feldon,	<i>Lias uplands</i>
Studley	Arden,	<i>Alne and Arrow valley floors</i>
Sutton-under-Brailes	Cotswold Fringe,	<i>Fringe downlands</i>
Tanworth-in-Arden	Arden,	<i>Ancient Arden</i>
Temple Grafton	Avon and Stour Valleys,	<i>Avon ridgelands</i>
Terry's Green	Arden,	<i>Birmingham plateau fringe</i>
Tiddington	Avon and Stour Valleys,	<i>Upper Avon</i>
Trapp's Green	Arden,	<i>Ancient Arden</i>
Tredington	Avon and Stour Valleys,	<i>Upper Stour</i>
Tysoe, Lower	Feldon,	<i>Clay vale</i>
Tysoe, Upper	Cotswold Fringe,	<i>Scarp foot and slope</i>
Ufton	Feldon,	<i>Lias uplands</i>
Upton	Cotswold Fringe,	<i>Ironstone plateau and valleylands</i>
Ullenhall	Arden,	<i>Ancient Arden</i>
Walcote	Arden,	<i>Alne and Arrow valley floors</i>
Waring's Green	Arden,	<i>Birmingham plateau fringe</i>
Warmington	Cotswold Fringe,	<i>Scarp foot and slope</i>
Welford-on-Avon	Avon and Stour Valleys,	<i>Avon vale</i>
Wellesbourne	Avon and Stour Valleys,	<i>Upper Avon</i>
Weston-on-Avon	Avon and Stour Valleys,	<i>Avon vale</i>
Whatcote	Feldon,	<i>Clay vale</i>
Whichford	Cotswold Fringe,	<i>Fringe downlands</i>
Willington	Avon and Stour Valleys,	<i>Upper Stour</i>
Wilmcote	Avon and Stour Valleys,	<i>Avon ridgelands</i>
Wimpstone	Avon and Stour Valleys,	<i>Stour vale</i>
Winderton	Cotswold Fringe,	<i>Scarp foot and slope</i>
Wixford	Avon and Stour Valleys,	<i>Avon and Arrow terraces</i>
Wolverton	Arden,	<i>Ancient Arden</i>
Wood End	Arden,	<i>Ancient Arden</i>
Wootton Wawen	Arden,	<i>Alne and Arrow valley floors</i>
Wormleighton	Feldon/Cotswold Fringe,	<i>outlying part of Scarp foot and slope</i>
Yarningale Common	Arden,	<i>Ancient Arden</i>

ARDEN

Trees		Woodland		Hedges	Wet areas
		clay	sand		
Field maple	<i>Acer campestre</i>	⊖			
Common alder	<i>Alnus glutinosa</i>	⊖			●
Silver birch	<i>Betula pendula</i>	⊖	●		
Downy birch	<i>Betula pubescens</i>	⊖			
Ash	<i>Fraxinus excelsior</i>	●			⊖
Holly	<i>Ilex aquifolium</i>	⊖	⊖		
Crab apple	<i>Malus sylvestris</i>	⊖	⊖		
Aspen	<i>Populus tremula</i>	⊖	⊖		⊖
Wild cherry	<i>Prunus avium</i>	⊖			
Sessile oak	<i>Quercus petraea</i>		●	●	
Pendunculate oak	<i>Quercus robur</i>	●	●	●	
White willow	<i>Salix alba</i>				●
Crack willow	<i>Salix fragilis</i>				●
Rowan	<i>Sorbus aucuparia</i>		⊖		
Small leaved lime	<i>Tilia cordata</i>	⊖			

Shrubs		Woodland		Hedges	Wet areas
		clay	sand		
Field maple	<i>Acer campestre</i>			⊖	
Dogwood	<i>Cornus sanguinea</i>	⊖		⊖	
Hazel	<i>Corylus avellana</i>	●		●	
Hawthorn	<i>Crataegus monogyna</i>	⊖	⊖	●	
Holly	<i>Ilex aquifolium</i>			⊖	
Wild privet	<i>Ligustrum vulgare</i>	⊖		⊖	
Blackthorn	<i>Prunus spinosa</i>	⊖		⊖	
Goat willow	<i>Salix caprea</i>	⊖	⊖		⊖
Guelder rose	<i>Viburnum opulus</i>	⊖		⊖	⊖

- Dominant species
- ⊖ Other appropriate species

AVON VALLEY

Trees		Woodland		Hedges	Wet areas
		clay	sand		
Field maple	<i>Acer campestre</i>	⊖		⊖	
Common alder	<i>Alnus glutinosa</i>	⊖			●
Silver birch	<i>Betula pendula</i>		●		
Ash	<i>Fraxinus excelsior</i>	●		●	⊖
Crab apple	<i>Malus sylvestris</i>	⊖	⊖		
Aspen	<i>Populus tremula</i>	⊖	⊖		⊖
Wild cherry	<i>Prunus avium</i>	⊖			
Pendunculate oak	<i>Quercus robur</i>	●	●	●	
White willow	<i>Salix alba</i>				●
Crack willow	<i>Salix fragilis</i>				●

Shrubs		Woodland		Hedges	Wet areas
		clay	sand		
Field maple	<i>Acer campestre</i>			⊖	
Dogwood	<i>Cornus sanguinea</i>	⊖		⊖	
Hazel	<i>Corylus avellana</i>	⊖		⊖	
Hawthorn	<i>Crataegus monogyna</i>	⊖	⊖	●	
Spindle	<i>Euonymus europaeus</i>	⊖		⊖	
Alder buckthorn	<i>Frangula alnus</i>	⊖		⊖	⊖
Wild Privet	<i>Ligustrum vulgare</i>	⊖		⊖	
Blackthorn	<i>Prunus spinosa</i>	⊖		⊖	
Purging buckthorn	<i>Rhamnus catharticus</i>	⊖		⊖	
Goat willow	<i>Salix caprea</i>	⊖	⊖		⊖
Osier	<i>Salix viminalis</i>				⊖
Elder	<i>Sambucus nigra</i>	⊖			
Wayfaring tree	<i>Viburnum lantana</i>	⊖		⊖	

- Dominant species
- ⊖ Other appropriate species

FELDON, STOUR VALLEY AND IRONSTONE UPLANDS

Trees		<i>Woodland</i>	<i>Hedges</i>	<i>Wet areas</i>
Field maple	<i>Acer campestre</i>	⊖	⊖	
Common alder	<i>Alnus glutinosa</i>	⊖		●
Ash	<i>Fraxinus excelsior</i>	●	●	⊖
Crab apple	<i>Malus sylvestris</i>	⊖		
Pendunculate oak	<i>Quercus robur</i>	●	●	
White willow	<i>Salix alba</i>			●
Crack willow	<i>Salix fragilis</i>			●

Shrubs		<i>Woodland</i>	<i>Hedges</i>	<i>Wet areas</i>
Field maple	<i>Acer campestre</i>		⊖	
Dogwood	<i>Cornus sanguinea</i>	⊖	⊖	
Hazel	<i>Corylus avellana</i>	⊖	⊖	
Hawthorn	<i>Crataegus monogyna</i>	⊖	●	
Spindle	<i>Euonymus europaeus</i>	⊖	⊖	
Wild privet	<i>Ligustrum vulgare</i>	⊖	⊖	
Blackthorn	<i>Prunus spinosa</i>	⊖	⊖	
Purging buckthorn	<i>Rhamnus catharticus</i>	⊖	⊖	
Goat willow	<i>Salix caprea</i>	⊖		⊖
Osier	<i>Salix viminalis</i>			⊖
Elder	<i>Sambucus nigra</i>	⊖		
Wayfaring tree	<i>Viburnum lantana</i>	⊖	⊖	

- Dominant species
- ⊖ Other appropriate species

COTSWOLD FRINGE

		Woodland		Hedges	Wet areas
		clay	sand		
Trees					
Field maple	<i>Acer campestre</i>		⊖		⊖
Common alder	<i>Alnus glutinosa</i>	⊖	⊖		●
Beech	<i>Fagus sylvatica</i>		●		
Ash	<i>Fraxinus excelsior</i>	●	●	●	⊖
Crab apple	<i>Malus sylvestris</i>	⊖	⊖		
Pendunculate oak	<i>Quercus robur</i>	●	●	●	
White willow	<i>Salix alba</i>				●
Crack willow	<i>Salix fragilis</i>				●

		Woodland		Hedges	Wet areas
		clay	sand		
Shrubs					
Field maple	<i>Acer campestre</i>			⊖	
Dogwood	<i>Cornus sanguinea</i>	⊖	⊖	⊖	
Hazel	<i>Corylus avellana</i>	⊖	⊖	⊖	
Hawthorn	<i>Crataegus monogyna</i>	⊖	⊖	●	
Spindle	<i>Euonymus europaeus</i>	⊖	⊖	⊖	
Wild privet	<i>Ligustrum vulgare</i>	⊖	⊖	⊖	
Blackthorn	<i>Prunus spinosa</i>	⊖	⊖	⊖	
Purging buckthorn	<i>Rhamnus catharticus</i>	⊖	⊖	⊖	
Goat willow	<i>Salix caprea</i>				⊖
Elder	<i>Sambucus nigra</i>	⊖			
Wayfaring tree	<i>Viburnum lantana</i>	⊖		⊖	

- Dominant species
- ⊖ Other appropriate species

Example of planting schedule and specification for screening

Trees	<i>Density</i>	<i>Size</i>
<i>Quercus robur</i>	5%	8-10cm girth, rootballed
<i>Fraxinus excelsior</i>	5%	8-10cm girth, rootballed
<i>Acer campestre</i>	5%	8-10cm girth
<i>Alnus glutinosa</i>	5%	8-10cm girth
<i>Malus sylvestris</i>	5%	8-10cm girth
Shrubs		
<i>Cornus sanguinea</i>	20%	60-90 Bare- root 1+2
<i>Corylus avellana</i>	20%	60-80 Bare-root 1+2
<i>Crataegus laevigata</i>	10%	60-80 Bare-root 1+2
<i>Euonymus europaeus</i>	15%	40-60 Bare-root 1+1
<i>Frangula alnus</i>	10%	40-60 Bare-root 1+1
Hedging Plants		
<i>Crataegus monogyna</i>	80%	40-60 Bare-root 1+1
<i>Ligustrum vulgare</i>	10%	40-60 Bare-root 1+1
<i>Prunus spinosa</i>	10%	40-60 Bare-root 1+1

Planting Densities

- All shrubs and trees to be planted on a 1 metre matrix with at least two metres between trees.
- Shrubs should be planted in groups of no less than 6 of the same species.
- Hedging to be planted at 5 plants per lin. metre in double staggered rows.

Specification

General Conditions

- Areas proposed for planting should have topsoil either stripped or protected during the construction period.

Earthworks

- Should it be necessary to strip topsoil in order to prevent compaction by construction traffic then subsoil should be ripped prior to replacement of topsoil.

Planting - General

- Ensure that all plants are obtained from a nursery which adheres to the HTA's Recommendations for Plant Handling

Tree Planting

- All trees to be single staked.
- Incorporate 50 litres of tree planting and mulching compost into backfilling soil and water each tree in with 50 litres of water.

Shrub Planting

- Incorporate 5 litres of planting and mulching compost into backfilling soil and water in with 5 litres of water.
- Planting holes should be at least 300mm diameter x 300mm deep.

Maintenance

- The maintenance and defects liability period for all planted areas is to extend for 5 years from practical completion of the landscape works.
- All areas are to be kept weed free for the duration of the maintenance period.
- All plants are to be protected from rabbit damage.

Planting Season

- NOVEMBER - MARCH (inclusive)

* Planting must not take place outside this period.

Cotswold Limestone

Broadway Limestone

Smiths Blethington Group

Broadway Quarry, Fish Hill,

Broadway

Worcester WR12 7LL

01386 852150

rough dressed stone, dressed stone and masonry units

Cotswold Stone Quarries

Brockhill Quarry

near Naunton

Cheltenham GL54 3BA

01451 850775

*also quarries at Swell Wold, Tinkers Barn and Syreford
stone tiles, rough dressed stone, dressed stone and
masonry units, dry walling stone*

The Downs Stone Co. Ltd.

Swailbrook House

Sarsden Halt

Churchill

Chipping Norton OX7 6NT

01608 659944

rough dressed stone, dressed stone and masonry units

Farmington Quarries

Northleach

Cheltenham GL54 3NZ

01451 860280

rough dressed stone, dressed stone and masonry units

Hanson's Aggregates

Guiting Quarry

Temple Guiting

near Winchcombe

Cheltenham GL54 5SB

01386 584285

rough dressed stone, dressed stone and masonry units

The Natural Stone Market

Grange Hill Quarry Ltd.

Naunton

Cheltenham GL54 3AY

01451 850864

stone tiles, rough dressed stone

Palmerstone Quarries

Soundborough Quarry

Andoversford

Cheltenham

01242 820135

rough dressed stone, dressed stone and masonry units

Stanley's Quarry

Northwick Estate

Upton Wold

near Moreton-in-Marsh GL56 9TR

01386 841236

rough dressed stone, dressed stone and masonry units

Tetbury Stone Co.

Veizy's Quarry

Avening Road

Tetbury GL8 8JT

01666 503455

*stone tiles, rough dressed stone, dressed stone and
masonry units*

Huntsmans Quarries Ltd.

The Old School

Naunton

Cheltenham

01451 850555

**Hornton' stone or Marlstone,
also referred to as Ironstone**

Avonhill Quarry
Avon Dassett
01295 770067

Peter Bennie Ltd.
Oxwhich Close
Brackmills Industrial Estate
Northampton NM4 7BH
01295 678127 office 01604 766101
operating quarry at Edgehill

C&W Knight
High Street
Fenny Compton
Leamington Spa CV33 0XT
01295 770313

Hornton Quarries Ltd.
Grange Lane
Edgehill
Banbury OX15 6DX
01295 670238/670750

White Lias (Langport Member Limestone)

*'Purbeck' stone from Somerset is in most instances an
acceptable alternative to White Lias*

Heritage Stone Company
Bartonbury Cottage
Chesterton Lane
Cirencester
Gloucestershire GL7 1XG
01285 644155

Webbs of Armscote Ltd.
Snug Cottage
Armscote
Stratford-upon-Avon CV37 8DL
01789 740271

Blue Lias

Heritage Stone Company
Bartonbury Cottage
Chesterton Lane
Cirencester
Gloucestershire GL7 1XG
01285 644155

Webbs of Armscote
Snug Cottage
Armscote
Stratford-upon-Avon CV37 8DL
01789 740271

Tout Quarry
Chessels Lane
Charlton Adam
Somerset TA11 7AN
01458 223179

Downslade Quarry Ltd.
Upton
Long Sutton
Langport
Somerset TA10 9NL
01458 241140

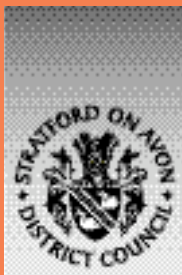

Planning

Elizabeth House, Church Street
Stratford-upon-Avon CV37 6HX

Telephone 01789 267575

Facsimile 01789 260306

Minicom 01789 260747

DX700737 STRATFORD-ON-AVON 2

e-mail planning@stratford-dc.gov.uk

website www.stratford.gov.uk